

# GEOPROBE® SCREEN POINT 15 GROUNDWATER SAMPLER

## STANDARD OPERATING PROCEDURE

Technical Bulletin No. MK3141

PREPARED: October, 1995

REVISED: November, 2007

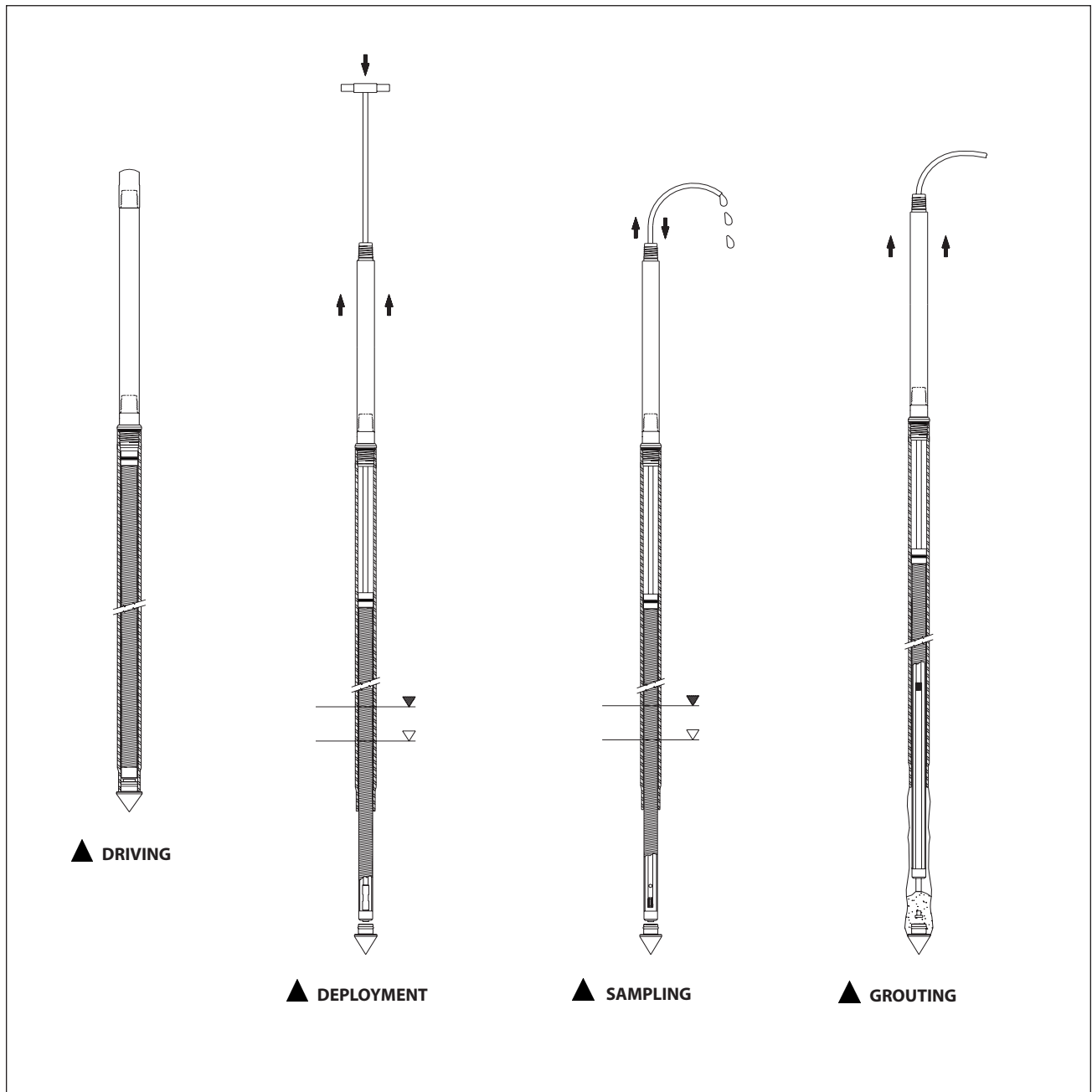

GEOPROBE® SCREEN POINT 15 GROUNDWATER SAMPLER



**Geoprobe® and Geoprobe Systems®, Macro-Core® and Direct Image® are  
Registered Trademarks of Kejr, Inc., Salina, Kansas**

**Screen Point 15 Groundwater Sampler is manufactured  
under U.S. Patent 5,612,498**

COPYRIGHT© 1995-2007 by Kejr, Inc.  
ALL RIGHTS RESERVED.

No part of this publication may be reproduced or transmitted in any form or by any means, electronic or mechanical, including photocopy, recording, or any information storage and retrieval system, without permission in writing from Kejr, Inc.

## 1.0 OBJECTIVE

The objective of this procedure is to drive a sealed stainless steel or PVC screen to depth, deploy the screen, obtain a representative water sample from the screen interval, and grout the probe hole during abandonment. The Screen Point 15 Groundwater Sampler enables the operator to conduct abandonment grouting that meets American Society for Testing and Materials (ASTM) Method D 5299 requirements for decommissioning wells and borings for environmental activities (ASTM 1993).

## 2.0 BACKGROUND

### 2.1 Definitions

**Geoprobe®:** A brand name of high quality, hydraulically powered machines that utilize both static force and percussion to advance sampling and logging tools into the subsurface. The Geoprobe® brand name refers to both machines and tools manufactured by Geoprobe Systems®, Salina, Kansas. Geoprobe® tools are used to perform soil core and soil gas sampling, groundwater sampling and monitoring, soil conductivity and contaminant logging, grouting, and materials injection.

**Screen Point 15 (SP15) Groundwater Sampler:** A direct push device consisting of a PVC or stainless steel screen that is driven to depth within a sealed, steel sheath and then deployed for the collection of representative groundwater samples. The assembled SP15 Sampler is approximately 50.5 inches (1283 mm) long with an OD of 1.5 inches (38 mm). Upon deployment, up to 41 inches (1041 mm) of screen can be exposed to the formation. The Screen Point 15 Groundwater Sampler is used primarily with 1.25-inch probe rods and machines equipped with a GH40 Series (GH40, GH41, or GH42) Hydraulic Hammer.

**Rod Grip Pull System:** An attachment mounted on the hydraulic hammer of a direct push machine which makes it possible to retract the tool string with extension rods or flexible tubing protruding from the top of the probe rods. The Rod Grip Pull System includes a pull block with rod grip jaws and two support straps that are bolted directly to the machine. A removable handle assembly straddles the tool string while hooking onto the pull block to effectively grip the probe rods as the hammer is raised. A separate handle assembly is required for each probe rod diameter.

### 2.2 Discussion

In this procedure, the assembled Screen Point 15 Groundwater Sampler (Fig. 2.1A) is threaded onto the leading end of a Geoprobe® probe rod and advanced into the subsurface with a Geoprobe® direct push machine. Additional probe rods are added incrementally and advanced until the desired sampling interval is reached. While the sampler is advanced to depth, O-ring seals at each rod joint, the drive head, and the expendable drive point provide a watertight system. This system eliminates the threat of formation fluids entering the screen before deployment and assures sample integrity.

Once at the desired sampling interval, extension rods are sent downhole until the leading rod contacts the bottom of the sampler screen. The tool string is then retracted approximately 44 inches (1118 mm) while the screen is held in place with the extension rods (Fig. 2.1B). As the tool string is retracted, the expendable point is released from the sampler sheath. The tool string and sheath may be retracted the full length of the screen or as little as a few inches if a small sampling interval is desired.

There are three types of screens that can be used in the Screen Point 15 Groundwater Sampler. Two of these, a stainless steel screen with a standard slot size of 0.004 inches (0.10 mm) and a PVC screen with a standard slot size of 0.010 inches (0.25 mm), are recovered with the tool string after sampling. The third screen is also manufactured from PVC with a standard slot size of 0.010 inches (0.25 mm), but is designed to be left downhole when sampling is complete. This disposable screen has an exposed screen length of approximately 43 inches (1092 mm). The two screens that are recovered with the sampler both have an exposed screen length of approximately 41 inches (1041 mm).

(continued on following page)

An O-ring on the head of the stainless steel screens maintains a seal at the top of the screen. As a result, any liquid entering the sampler during screen deployment must first pass through the screen. PVC screens do not require an O-ring because the tolerance between the screen head and sampler sheath is near that of the screen slot size.

The screens are constructed such that flexible tubing, a mini-bailer, or a small-diameter bladder pump can be inserted into the screen cavity. This makes direct sampling possible from anywhere within the saturated zone. A removable plug in the lower end of the screens allows the user to grout as the sampler is extracted for further use.

Groundwater samples can be obtained in a number of ways. A common method utilizes polyethylene (TB25L) or Teflon® (TB25T) tubing and a Check Valve Assembly (GW4210). The check valve (with check ball) is attached to one end of the tubing and inserted down the casing until it is immersed in groundwater. Water is pumped through the tubing and to the ground surface by oscillating the tubing up and down.

An alternative means of collecting groundwater samples is to attach a peristaltic or vacuum pump to the tubing. This method is limited in that water can be pumped to the surface from a maximum depth of approximately 26 feet (8 m). Another technique for groundwater sampling is to use a stainless steel Mini-Bailer Assembly (GW41). The mini-bailer is lowered down the inside of the casing below the water level where it fills with water and is then retrieved from the casing.

The latest option for collecting groundwater from the SP15 sampler is to utilize a Geoprobe® MB470 Series Mechanical Bladder Pump (MBP)\*. The MBP may be used to meet requirements of the low-flow sampling protocol (Puls and Barcelona 1996, ASTM 2003). Through participation in a U.S. EPA Environmental Technology Verification study, it was confirmed that the MB470 can provide representative samples (EPA 2003).

*\*The Mechanical Bladder Pump is manufactured under U.S. Patent No. 6,877,965 issued April 12, 2005.*

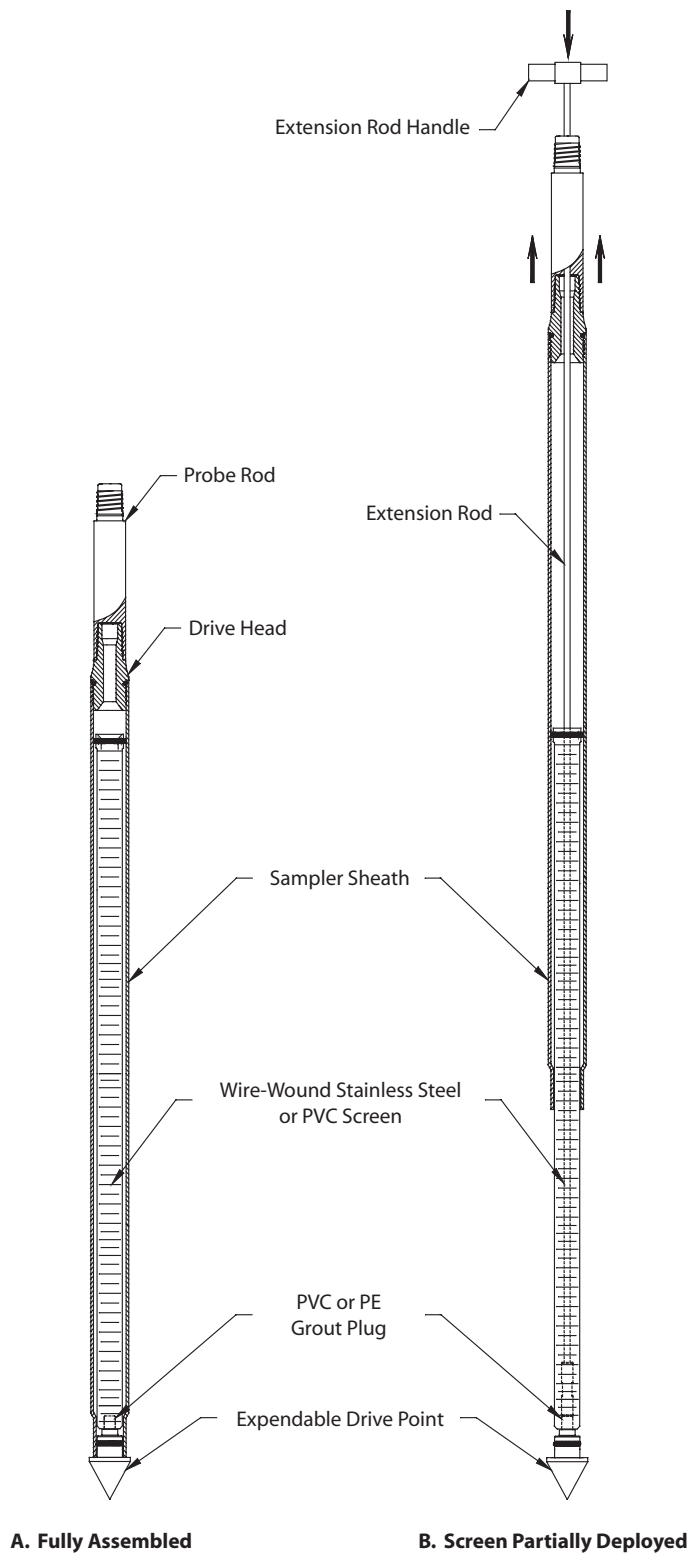

**FIGURE 2.1**  
**Screen Point 15 Groundwater Sampler**

### 3.0 TOOLS AND EQUIPMENT

The following tools and equipment can be used to successfully recover representative groundwater samples with the Geoprobe® Screen Point 15 Groundwater Sampler. Refer to Figures 3.1 and 3.2 for identification of the specified parts. Tools are listed below for the most common SP15 / 1.25-inch probe rod configuration. Additional parts for optional rod sizes and accessories are listed in Appendix A.

<b>SP15 Sampler Parts</b>	<b>Part Number</b>
SP15 Sampler Sheath.....	GW1510
SP15 Drive Head, 0.625-inch bore, 1.25-inch rods* .....	GW1512
Screen, Wire-Wound Stainless Steel, 4-Slot* .....	GW1520
SP15 O-ring Service Kit, 1.25-inch rods ( <i>includes 4 each of the O-ring packets below</i> ).....	GW1505K
<i>O-rings for Top of SP15 Drive Head, 1.25-inch rods only (Pkt. of 25)</i> .....	<i>AT1250R</i>
<i>O-rings for Bottom of SP15 Drive Head (Pkt. of 25)</i> .....	<i>GW1516R</i>
<i>O-rings for GW1520 Screen Head (Pkt. of 25)</i> .....	<i>GW1520R</i>
<i>O-rings for SP15 Expendable Drive Point (Pkt. of 25)</i> .....	<i>GW1555R</i>
Grout Plugs, PE (Pkg. of 25) .....	GW1552K
Expendable Drive Points, steel, 1.625-inch OD (Pkg. of 25)* .....	GW1555K
Screen Point 15 Groundwater Sampler Kit, 1.25-inch Probe Rods ( <i>includes 1 each of:</i> <i>GW1505K, GW1510, GW1513, GW1520, GW1535, GW1540, GW1552K, and GW1555K</i> ) .....	GW1512K

<b>Probe Rods and Probe Rod Accessories</b>	<b>Part Number</b>
Drive Cap, 1.25-inch probe rods, (for GH40 Series Hammer) .....	AT1200
Pull Cap, 1.25-inch probe rods.....	AT1204
Probe Rod, 1.25-inch x 48-inch* .....	AT1248
Rod Grip Pull System, 1.0-/1.25-inch probe rods (for GH40 Series Hammer) .....	GH1250K

<b>Extension Rods and Extension Rod Accessories</b>	<b>Part Number</b>
Screen Push Adapter.....	GW1535
Grout Plug Push Adapter.....	GW1540
Extension Rod, 48-inch* .....	AT671
Extension Rod Coupler.....	AT68
Extension Rod Jig.....	AT690
Extension Rod Quick Link Coupler, pin.....	AT695
Extension Rod Quick Link Coupler, box.....	AT696

<b>Grout Accessories</b>	<b>Part Number</b>
Grout Nozzle, for 0.375-inch OD tubing.....	GW1545
High-Pressure Nylon Tubing, 0.375-inch OD / 0.25-inch ID, 100-ft. (30 m).....	11633
Grout Machine, self-contained* .....	GS1000
Grout System Accessories Package, 1.25-inch rods .....	GS1012

<b>Groundwater Purging and Sampling Accessories</b>	<b>Part Number</b>
Polyethylene Tubing, 0.375-inch OD, 500 ft.* .....	TB25L
Check Valve Assembly, 0.375-inch OD Tubing* .....	GW4210
Water Level Meter, 0.438-inch OD Probe, 100 ft. cable* .....	GW2000
Mechanical Bladder Pump** .....	MB470
Mini Bailer Assembly, stainless steel .....	GW41

<b>Additional Tools</b>	<b>Part Number</b>
Adjustable Wrench, 6.0-inch .....	FA200
Adjustable Wrench, 10.0-inch .....	FA201
Pipe Wrenches .....	NA

\* See Appendix A for additional tooling options.

\*\* Refer to the Standard Operating Procedure (SOP) for the Mechanical Bladder Pump (Technical Bulletin No. MK3013) for additional tooling needs.

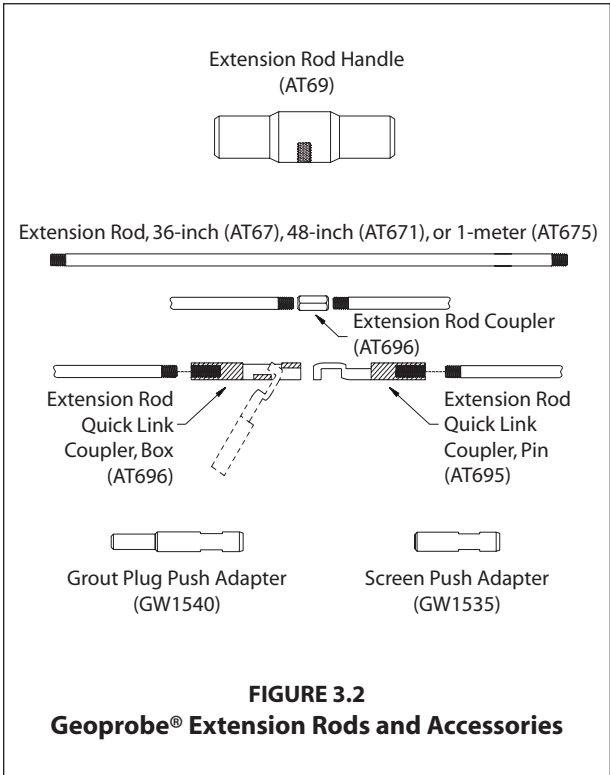
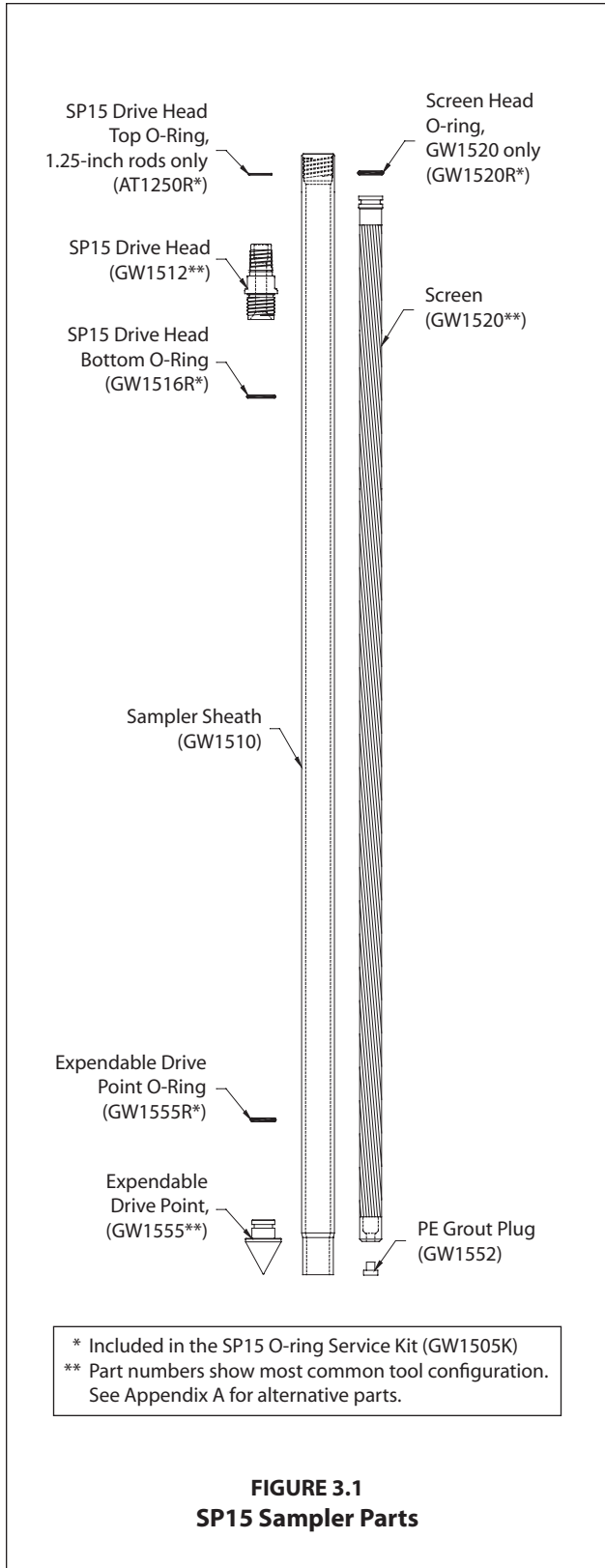

## 4.0 OPERATION

### 4.1 Basic Operation

The SP15 sampler utilizes a stainless steel or PVC screen which is encased in an alloy steel sampler sheath. An expendable drive point is placed in the lower end of the sheath while a drive head is attached to the top. O-rings on the drive head and expendable point provide a watertight sheath which keeps contaminants out of the system as the sampler is driven to depth.

Once the sampling interval is reached, extension rods equipped with a screen push adapter are inserted down the ID of the probe rods. The tool string is then retracted up to 44 inches (1118 mm) while the screen is held in place with the extension rods. The system is now ready for groundwater sampling. When sampling is complete, a removable plug in the bottom of the screen allows for grouting below the sampler as the tool string is retrieved.

### 4.2 Sampler Options

The Screen Point 15 and Screen Point 16 Groundwater samplers are nearly identical. Subtle differences in the design of the SP16 sampler makes it more durable than the earlier SP15 system. Operators of GH60-equipped machines should always utilize SP16 tooling. Operators of machines equipped with GH40 Series hammers may also choose SP16 tooling when sampling in difficult probing conditions.

A 1.75-inch OD Expendable Drive Point (17066K) and Disposable PVC Screen (16089) provide two useful options for the SP15 sampler. The 1.75-inch drive point may be used when soil conditions make it difficult to remove the sampler after driving to depth. The disposable PVC screen may be left downhole after sampling (when regulations permit) to eliminate the time required for screen decontamination.

### 4.3 Decontamination

In order to collect representative groundwater samples, all sampler parts must be thoroughly cleaned before and after each use. Scrub all metal parts using a stiff brush and a nonphosphate soap solution. Steam cleaning may be substituted for hand-washing if available. Rinse with distilled water and allow to air-dry before assembly.

### 4.4 SP15 Sampler Assembly (Figure 4.1)

Part numbers are listed for a standard SP15 sampler using 1.25-inch probe rods. Refer to Page 6 for screen and drive head alternatives.

1. Place an O-ring on a Steel Expendable Drive Point (GW1555). Firmly seat the expendable point in the necked end of a Sampler Sheath (GW1510).
2. Install a PE Grout Plug (GW1552) in the lower end of a Wire-wound Stainless Steel Screen (GW1520). Place a GW1520R O-ring in the groove on the upper end of the screen.
3. Slide the screen inside the sampler sheath with the grout plug toward the bottom of the sheath. Lubricate the O-ring with distilled water if needed. Ensure that the expendable point is not displaced by the screen.
4. Install a bottom O-ring (GW1516R) on a Drive Head (GW1512). Thread the drive head into the sampler sheath using an adjustable wrench if necessary to ensure complete engagement of the threads. Attach a Drive Cap (AT1200) to the top of the drive head.

**Sampler assembly is complete**



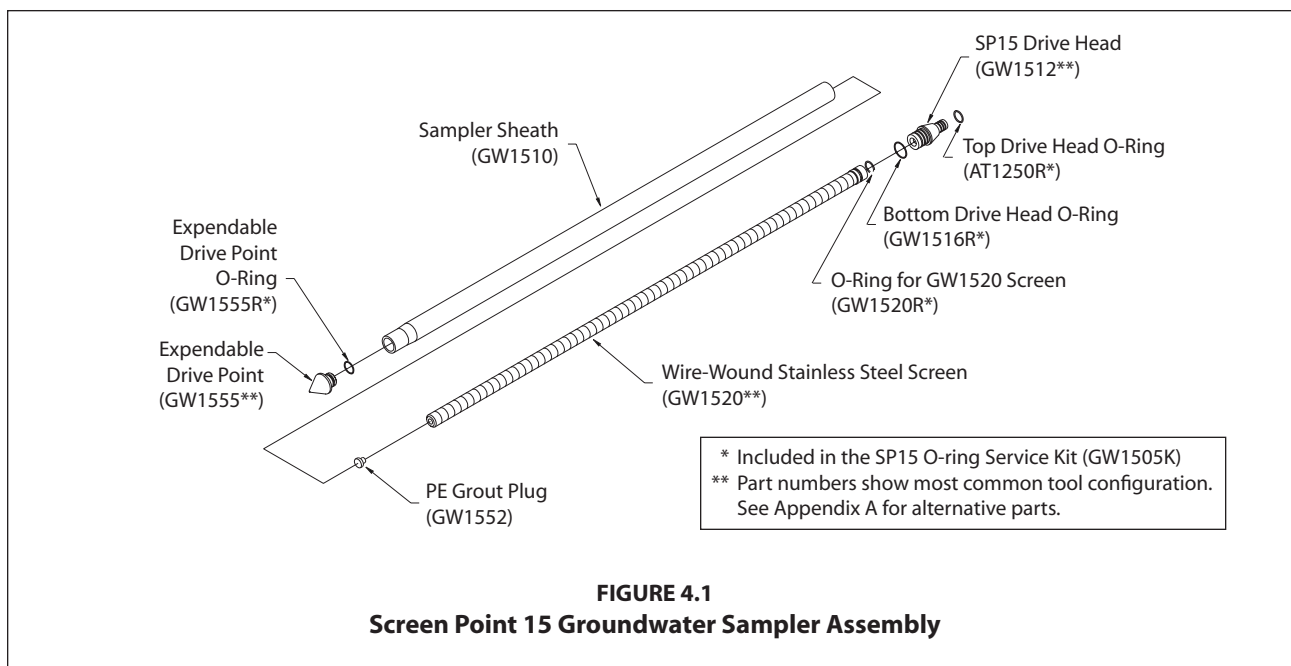

#### 4.5 Advancing the SP15 Sampler

To provide adequate room for screen deployment with the Rod Grip Pull System, the probe derrick should be extended a little over halfway out of the carrier vehicle when positioning for operation.

1. Begin by placing the assembled sampler (Fig. 2.1.A) in the driving position beneath the hydraulic hammer of the direct push machine as shown in Figure 4.2.
2. Advance the sampler with the throttle control at slow speed for the first few feet to ensure that the sampler is aligned properly. Switch to fast speed for the remainder of the probe stroke.

3. Completely raise the hammer assembly. Remove the drive cap and place an O-ring in the top groove of the drive head. Distilled water may be used to lubricate the O-ring if needed.

Add a probe rod (length to be determined by operator) and reattach the drive cap to the rod string. Drive the sampler the entire length of the new rod with the throttle control at fast speed.

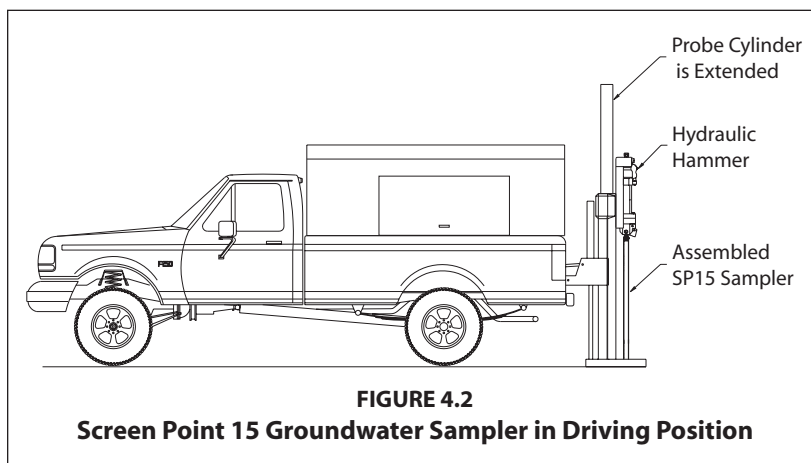

4. Repeat Step 3 until the desired sampling interval is reached. Approximately 12 inches (305 mm) of the last probe rod must extend above the ground surface to allow attachment of the puller assembly. A 12-inch (305 mm) rod may be added if the tool string is over-driven.
5. Remove the drive cap and retract the probe derrick away from the tool string.

## 4.6 Screen Deployment

1. Thread a Screen Push Adapter (GW1535) onto an extension rod of suitable length (AT67, AT671, or AT675). Attach a threaded coupler (AT68) to the other end of the extension rod. Lower the extension rod inside the tool string taking care not to drop it downhole.
2. Add extension rods until the adapter contacts the bottom of the screen. To speed up this step, it is recommended that Extension Rod Quick Links (AT695 and AT696) are used at every other rod joint.
3. Ensure that at least 48 inches (1219 mm) of extension rod protrudes from the probe rod. Thread an extension rod handle (AT69) on the top extension rod.
4. Maneuver the probe assembly into position for pulling.
5. Raise (pull) the tool string while physically holding the screen in place with the extension rods (Fig. 4.3.B). A slight knock with the extension rod string will help to dislodge the expendable point and start the screen moving inside the sheath.

Raise the hammer and tool string about 44 inches (1118 mm) if using a GW1520 or GW1530 screen. At this point the screen head will contact the necked portion of the sampler sheath (Fig. 4.3.C.) and the extension rods will rise with the probe rods. Use care when deploying a PVC screen so as not to break the screen when it contacts the bottom of the sampler sheath.

The Disposable Screen (16089) will extend completely out of the sheath if the tool string is raised more than 45 inches (1143 mm). Measure and mark this distance on the top extension rod to avoid losing the screen during deployment.

6. Remove the rod grip handle, lower the hammer assembly, and retract the probe derrick. Remove the top extension rod (with handle) and top probe rod. Finally, extract all extension rods.
7. Groundwater samples can now be collected with a mini-bailer, peristaltic or vacuum pump, check valve assembly, mechanical bladder pump, or other acceptable small diameter sampling device.

When inserting tubing or a bladder pump down the rod string, ensure that it enters the screen interval. The leading end of the tubing or bladder pump will sometimes catch at the screen head giving the illusion that the bottom of the screen has been reached. An up-and-down motion combined with rotation helps move the tubing or bladder pump past the lip and into the screen.

## 4.7 Abandonment Grouting for GW1520 and GW1530 Screens

The SP15 Groundwater Sampler can meet ASTM D 5299 requirements for abandoning environmental wells or borings when grouting is conducted properly. A removable grout plug makes it possible to deploy tubing through the bottom of GW1520 and GW1530 screens. A GS500 or GS1000 Grout Machine is then used to pump grout into the open probe hole as the sampler is withdrawn. The following procedure is presented as an example only and should be modified to satisfy local abandonment grouting regulations.

1. Maneuver the probe assembly into position for pulling. Attach the rod grip puller to the top probe rod. Raise the tool string approximately 4 to 6 inches (102 to 152 mm) to allow removal of the grout plug.
2. Thread the Grout Plug Push Adapter (GW1540) onto an extension rod. Insert the adapter and extension rod inside the probe rod string. Add extension rods until the adapter contacts the grout plug at the bottom of the screen. Attach the handle to the top extension rod. When the extension rods are slightly raised and lowered, a relatively soft rebound should be felt as the adapter contacts the grout plug. This is especially true when using a PVC screen.

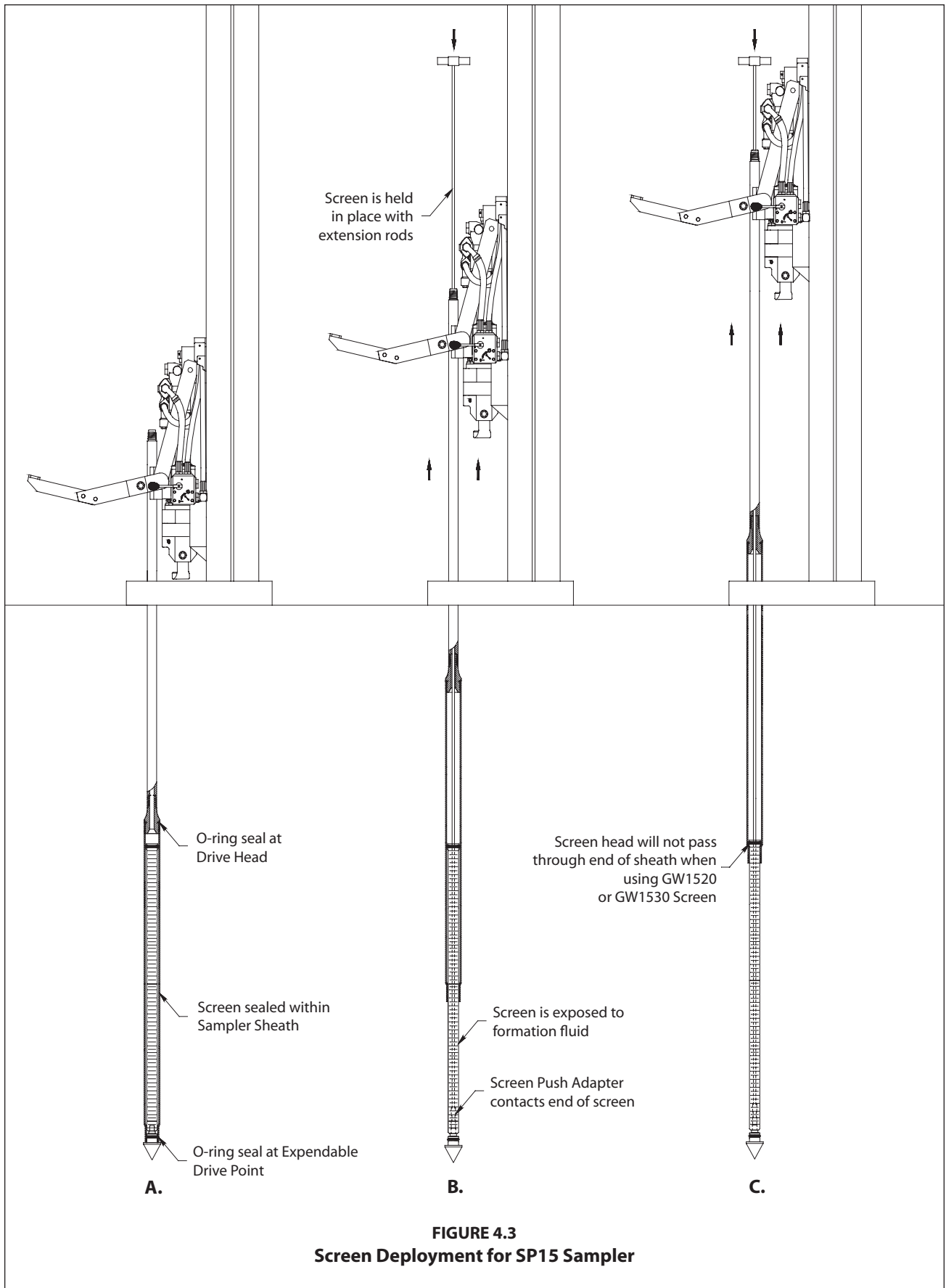

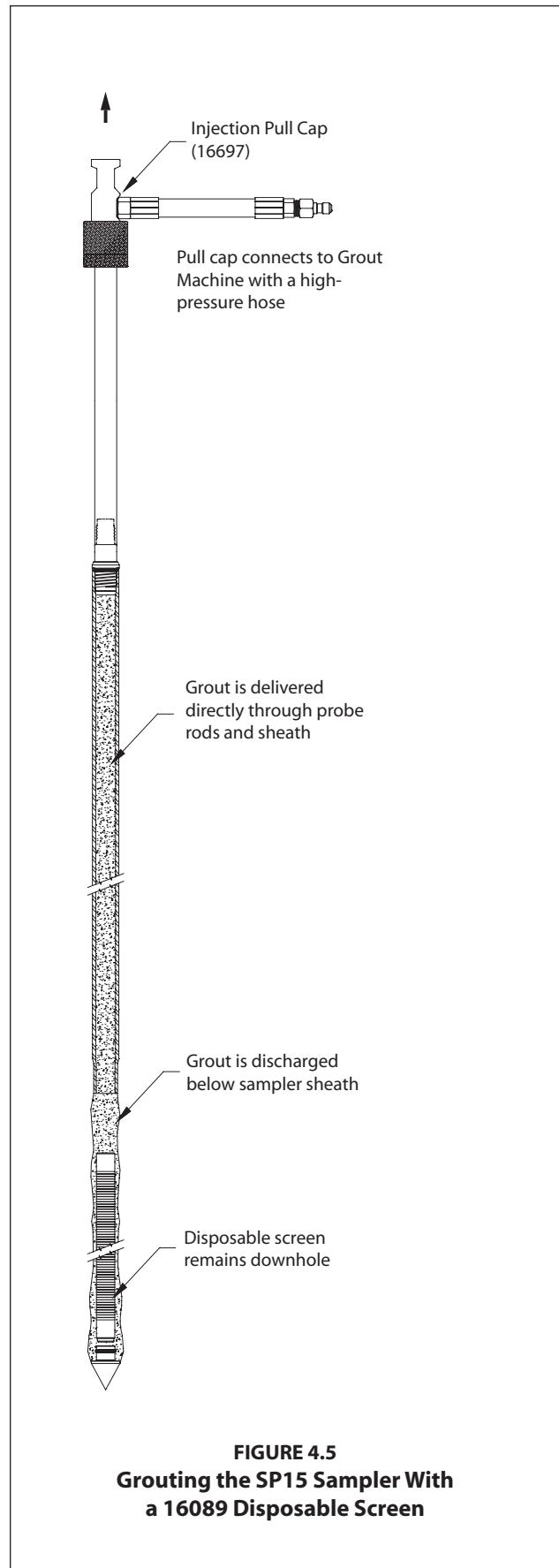
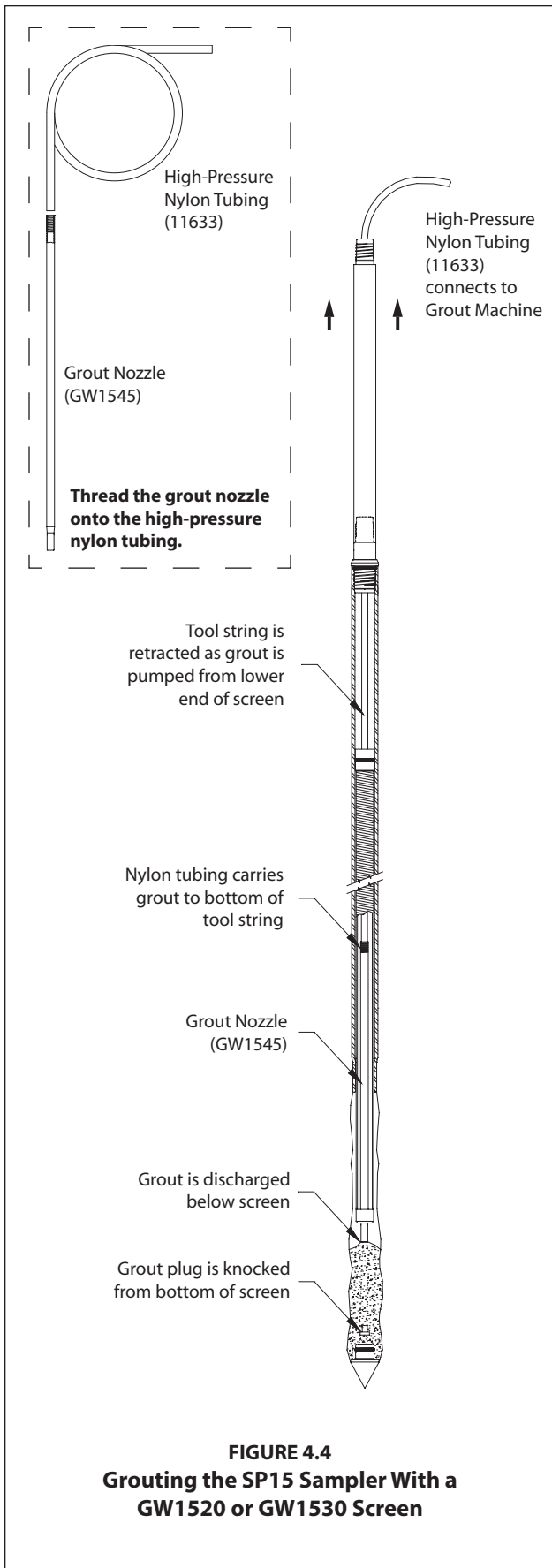

3. Place a mark on the extension rod even with the top of the probe rod. Apply downward pressure on the extension rods and push the grout plug out of the screen. The mark placed on the extension rod should now be below the top of the probe rod. Remove all extension rods.

**Note:** When working with a stainless steel screen, it may be necessary to raise and quickly lower the extension rods to jar the grout plug free. When the plug is successfully removed, a metal-on-metal sensation may be noted as the extension rods are gently "bounced" within the probe rods.

4. A Grout Nozzle (GW1545) is now connected to High-Pressure Nylon Tubing (11633) and inserted down through the probe rods to the bottom of the screen (Fig. 4.4). It may be necessary to pump a small amount of clean water through the tubing during deployment to jet out sediments that settled in the bottom of the screen. Resistance will sometimes be felt as the grout nozzle passes through the drive head. Rotate the tubing while moving it up-and-down to ensure that the nozzle has reached the bottom of the screen and is not hung up on the drive head.

**Note:** All probe rods remain strung on the tubing as the tool string is pulled. Provide extra tubing length to allow sufficient room to lay the rods on the ground as they are removed. An additional 20 feet is generally enough.

5. Operate the grout pump while pulling the first rod with the rod grip pull system. Coordinate pumping and pulling rates so that grout fills the void left by the sampler. After pulling the first rod, release the rod grip handle, fully lower the hammer, and regrip the tool string. Unthread the top probe and slide it over the tubing placing it on the ground near the end of the tubing.
6. Repeat Step 5 until the sampler is retrieved. Do not bend or kink the tubing when pulling and laying out the probe rods. Sharp bends create weak spots in the tubing which may burst when pumping grout. Remember to operate the grout pump only when pulling the rod string. The probe hole is thus filled with grout from the bottom up as the rods are extracted.
7. Promptly clean all probe rods and sampler parts before the grout sets up and clogs the equipment.

#### 4.8 Abandonment Grouting for the 16089 Disposable Screen

ASTM D 5299 requirements can also be met for the SP15 sampler when using the 16089 disposable screen. Because the screen remains downhole after sampling, the operator may choose either to deliver grout to the bottom of the tool string with nylon tubing or pump grout directly through the probe rods using an Injection Pull Cap (16697). A GS500 or GS1000 Grout Machine is needed to pump grout into the open probe hole as the sampler is withdrawn. The following procedure is presented as an example only and should be modified to satisfy local abandonment grouting regulations.

1. Maneuver the probe assembly into position for pulling with the rod grip puller.
2. Thread the screen push adapter onto an extension rod. Insert the adapter and extension rod inside the probe rod string. Add extension rods until the adapter contacts the bottom of the screen. Attach the handle to the top extension rod.
3. The disposable screen must be extended at least 46 inches (1168 mm) to clear the bottom of the sampler sheath. Considering the length of screen deployed in Section 4.6, determine the remaining distance required to fully extend the screen from the sheath. Mark this distance on the top extension rod.
4. Pull the tool string up to the mark on the top extension rod while holding the disposable screen in place.

The screen is now fully deployed and the sampler is ready for abandonment grouting. Apply grout to the bottom of the tool string during retrieval using either flexible tubing (as described in Section 4.7) or an injection pull cap (Fig. 4.5). This section continues with a description of grouting with a pull cap.

5. Remove the rod grip handle and maneuver the probe assembly directly over the tool string. Thread an Injection Pull Cap (16697) onto the top probe rod and close the hammer pull latch over the top of the pull cap.
6. Connect the pull cap to a Geoprobe® grout machine using a high-pressure grout hose.
7. Operate the pump to fill the entire tool string with grout. When a sufficient volume has been pumped to fill the tool string, begin pulling the rods and sampler while continuing to operate the grout pump. Considering the known pump volume and sampler cross-section, time tooling withdrawal to slightly "overpump" grout into the subsurface. This will ensure that all voids are filled during sampler retrieval.

The grouting process can lubricate the probe hole sufficiently to cause the tool string to slide back downhole when disconnected from the pull cap. Prevent this by withdrawing the tool string with the rod grip puller while maintaining a connection to the grout machine with the pull cap.

#### 4.9 Retrieving the Screen Point 15 Sampler

If grouting is not required, the Screen Point 15 Sampler can be retrieved by pulling the probe rods as with most other Geoprobe® applications. The Rod Grip Pull System should be used for this process as it allows the operator to remove rods without completely releasing the tool string. This avoids having the probe rods fall back downhole when released during the pulling procedure. A standard Pull Cap (AT1204) may still be used if preferred. Refer to the Owner's Manual for your Geoprobe® direct push machine for specific instructions on pulling the tool string.

#### 5.0 REFERENCES

- American Society of Testing and Materials (ASTM), 2003. D6771-02 Standard Practice for Low-Flow Purging and Sampling for Wells and Devices Used for Ground-Water Quality Investigations. ASTM, West Conshohocken, PA. ([www.astm.org](http://www.astm.org))
- American Society of Testing and Materials (ASTM), 1993. ASTM 5299 *Standard Guide for Decommissioning of Groundwater Wells, Vadose Zone Monitoring Devices, Boreholes, and Other Devices for Environmental Activities*. ASTM West Conshohocken, PA. ([www.astm.org](http://www.astm.org))
- Geoprobe Systems®, 2003, *Tools Catalog, V.6*.
- Geoprobe Systems®, 2006, *Model MB470 Mechanical Bladder Pump Standard Operating Procedure (SOP), Technical Bulletin No. MK3013*.
- Puls, Robert W., and Michael J. Barcelona, 1996. Ground Water Issue: Low-Flow (Minimal Drawdown) Ground Water Sampling Procedures. EPA/540/S-95/504. April.
- U.S. Environmental Protection Agency (EPA), 2003. Environmental Technology Verification Report: Geoprobe Inc., Mechanical Bladder Pump Model MB470. Office of Research and Development, Washington, D.C. EPA/600R-03/086. August.

## Appendix A ALTERNATIVE PARTS

The following parts are available to meet unique soil conditions. See section 3.0 for a complete listing of the common tool configurations for the Geoprobe® Screen Point 15 Groundwater Samplers.

<b>SP15 Sampler Parts and Accessories.....</b>	<b>Part Number</b>
SP15 Drive Head, 0.5-inch bore, 1.25-inch rods.....	GW1513
SP15 Drive Head, 0.625-inch bore, 1.5-inch rods.....	14998
SP15 Drive Head, 1.0-inch rods.....	GW1515
Expendable Drive Points, aluminum, 1.625-inch OD (Pkg. of 25).....	GW1555ALK
Expendable Drive Points, steel, 1.75-inch OD (Pkg. of 25).....	17066K
Screen, PVC, 10-Slot.....	GW1530
Screen, Disposable, PVC, 10-Slot.....	16089

<b>Groundwater Purging and Sampling Accessories .....</b>	<b>Part Number</b>
Polyethylene Tubing, 0.25-inch OD, 500 ft.....	TB17L
Polyethylene Tubing, 0.5-inch OD, 500 ft.....	TB37L
Check Valve Assembly, 0.25-inch OD Tubing.....	GW4240
Check Valve Assembly, 0.5-inch OD Tubing.....	GW4220
Check Valve Assembly, 0.625-inch OD Tubing.....	GW4230
Water Level Meter, 0.375-inch OD Probe, 100-ft. cable.....	GW2001
Water Level Meter, 0.438-inch OD Probe, 200-ft. cable.....	GW2002
Water Level Meter, 0.375-inch OD Probe, 200-ft. cable.....	GW2003
Water Level Meter, 0.438-inch OD Probe, 30-m cable.....	GW2005
Water Level Meter, 0.438-inch OD Probe, 60-m cable.....	GW2007
Water Level Meter, 0.375-inch OD Probe, 60-m cable.....	GW2008

<b>Grouting Accessories.....</b>	<b>Part Number</b>
Grout Machine, auxiliary-powered.....	GS500

<b>Probe Rods, Extension Rods, and Accessories .....</b>	<b>Part Number</b>
Probe Rod, 1.25-inch x 36-inch.....	AT1236
Probe Rod, 1.25-inch x 1-meter.....	AT1239
Probe Rod, 1.5-inch x 1-meter.....	17899
Probe Rod, 1.5-inch x 48-inch.....	13359
Drive Cap, 1.5-inch rods (for GH40 Series Hammer).....	15590
Rod Grip Pull Handle, 1.5-inch Probe Rods (for GH40 Series Hammer).....	GH1555
Extension Rod, 36-inch.....	AT67
Extension Rod, 1-meter.....	AT675

Equipment and tool specifications, including weights, dimensions, materials, and operating specifications included in this brochure are subject to change without notice. Where specifications are critical to your application, please consult Geoprobe Systems®.



A DIVISION OF KEJR, INC.

**Corporate Headquarters**

601 N. Broadway • Salina, Kansas 67401  
1-800-GEOPROBE (1-800-436-7762) • Fax (785) 825-2097  
[www.geoprobe.com](http://www.geoprobe.com)