

GEOPROBE® DT325 DUAL TUBE SAMPLING SYSTEM

STANDARD OPERATING PROCEDURE

Technical Bulletin No. MK3138

PREPARED: November, 2006

REVISED: January, 2011

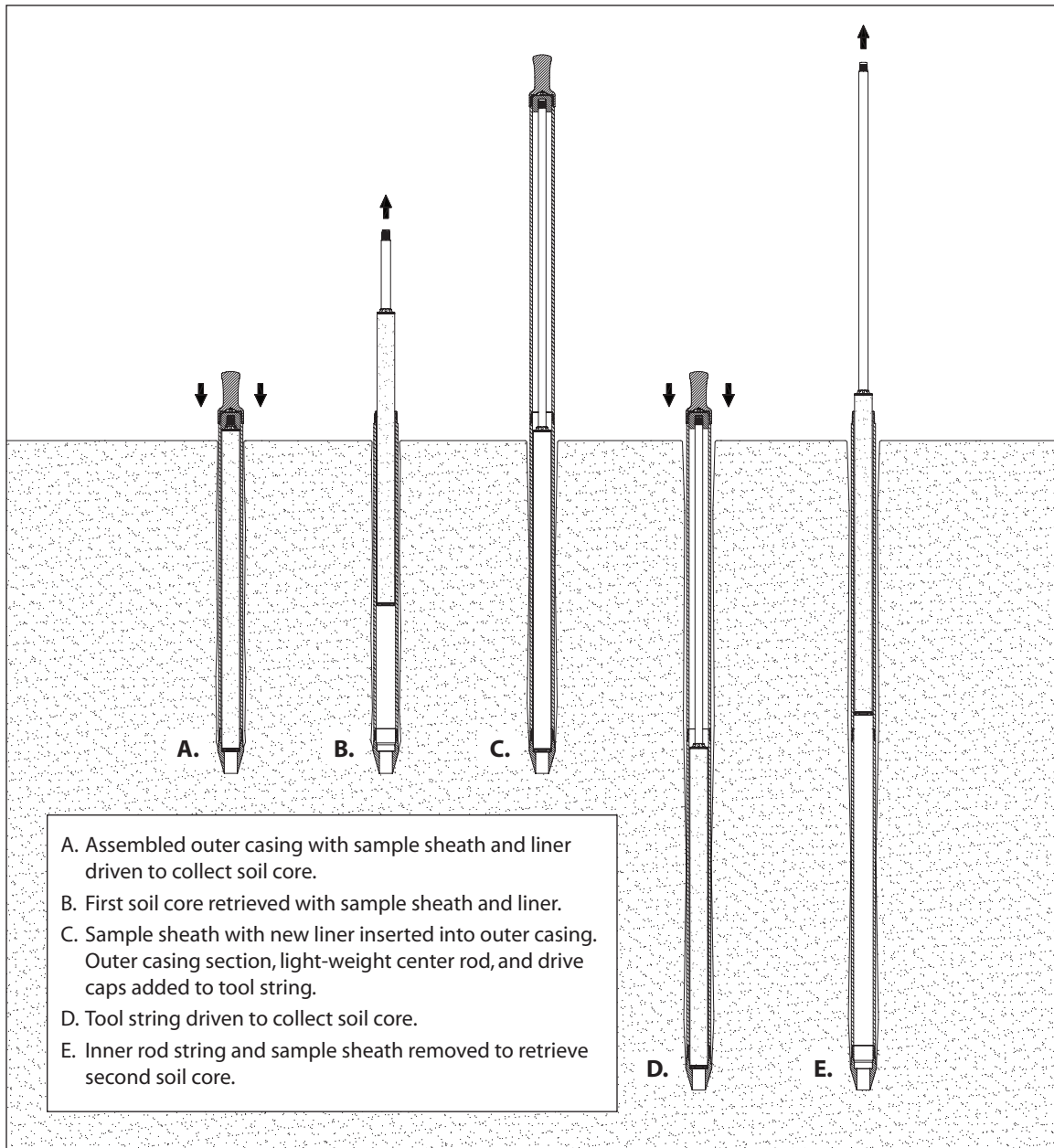

Collecting soil cores with the DT325 Dual Tube Sampling System.



**Geoprobe® and Geoprobe Systems®, Macro-Core®, and Direct Image®
are Registered Trademarks of Kejr, Inc., Salina, Kansas**

**Geoprobe® Prepacked Screens are manufactured under
U.S. Patent No. 7,735,553B2.**

©2006-2011 Kejr, Inc.

ALL RIGHTS RESERVED

No part of this publication may be reproduced or transmitted in any form or by any means, electronic or mechanical, including photocopy, recording, or any information storage and retrieval system, without written permission from Kejr, Inc.

1.0 Objective

The objective of this procedure is to collect a representative soil sample at depth through an enclosed casing and recover it for visual inspection and/or chemical analysis.

2.0 Background

2.1 Definitions

Geoprobe®: A brand name of high quality, hydraulically-powered machines that utilize both static force and percussion to advance sampling and logging tools into the subsurface. The Geoprobe® brand name refers to both machines and tools manufactured by Geoprobe Systems®, Salina, Kansas. Geoprobe® tools are used to perform soil core and soil gas sampling, groundwater sampling and testing, soil conductivity and contaminant logging, grouting, and materials injection.

**Geoprobe® and Geoprobe Systems® are registered trademarks of Kejr, Inc., Salina, Kansas.*

DT325 Dual Tube Sampling System: A direct push system for collecting continuous core samples of unconsolidated materials from within a sealed casing of Geoprobe® 3.25-inch (83 mm) OD probe rods. Samples are collected and retrieved within a sample sheath and liner that is threaded onto the leading end of a string of Geoprobe® 1.25-inch (32 mm) OD light-weight center rods and inserted to the bottom of the outer casing. Collected samples measure up to approximately 2,600 ml in volume in the form of a 1.85-inch x 59-inch (47 mm x 1499 mm) core when using common equipment options.

Liner: A 2.1-inch (53 mm) OD thin-walled, PVC tube that is placed within a steel sheath and then inserted into the outer casing on the leading end of the inner rod string for the purpose of containing and retrieving core samples. Liners are available in two configurations; a simple open tube or a tube with a core catcher permanently attached to the leading end. Nominal liner lengths include 1 meter, 48 inches, and 60 inches.

***Nominal liner length identifies the length of tools with which the liner is used. The actual end-to-end lengths of the various DT325 liners will differ from the specified nominal lengths.*

Core Catcher: A dome-shaped device positioned at the leading end of a liner to prevent loss of collected soil during retrieval of the liner and soil core. Flexible fingers at the top of the core catcher are pushed outward by soil entering the liner during advancement of the tool string. As the filled liner is subsequently retrieved, the fingers of the core catcher move back inward, effectively closing off the end of the liner and limiting soil loss. The core catcher designed for the DT325 system is permanently fused to the liner.

2.2 Discussion

Dual tube sampling gets its name from the fact that two sets of probe rods are used to retrieve continuous soil core samples from the subsurface. One set of rods is driven into the ground as an outer casing (Fig. 2.1). These rods receive the driving force from the hammer and provide a sealed casing through which soil samples may be recovered. The second, smaller set of rods are placed inside the outer casing with a sample liner attached to the leading end of the rod string (Fig. 2.1). These smaller rods hold the liner in place as the outer casing is driven to fill the liner with soil. The inner rods are then retracted to retrieve the full liner.

Standard Geoprobe® 3.25-inch OD probe rods provide the outer casing for the DT325 Dual Tube Soil Sampling System. A cutting shoe is threaded into the leading end of the rod string. When driven into the subsurface, the cutting shoe shears a 1.75- or 1.85-inch OD soil core (depending on cutting shoe option) which is collected inside the casing in a PVC liner.

The second set of rods in the DT325 dual tube system are Geoprobe® 1.25-inch OD light-weight center rods. A sample sheath with PVC liner is attached to the end of these smaller rods and then inserted into the casing. The 1.25-inch light-weight center rods hold the sample sheath tight against the cutting shoe as the outer casing is driven to collect the soil core. Once filled with soil, the sample sheath and liner are removed from the bottom of the outer casing by lifting out the 1.25-inch center rod string.

The outer, 3.25-inch probe rods provide a cased hole through which to sample. The main advantage of sampling through a cased hole is that there is no side slough to contend with. In addition, the outer casing effectively seals the probe hole when sampling through perched water tables. These factors mean that sample cross-contamination is eliminated. The DT325 sampling system is therefore ideal for continuous coring in both saturated and unsaturated zones.

Solid Drive Tip

A Solid Drive Tip (28509 or 27763) can be placed on the leading end of the inner 1.25-inch rod string in place of a sample sheath and liner (Fig.2.2). When installed in the outer casing, the drive tip firmly seats within the cutting shoe and effectively seals the tool string as it is driven into the subsurface. This enables the operator to advance the outer casing to the bottom of a pre-cored hole or through undisturbed soil to reach the top of the sampling interval.

Grouting

The DT325 system allows bottom-up grouting through the primary tool string. This means that a cement or bentonite grout mix can be pumped through the outer casing as it is withdrawn from the ground. This is in contrast to most other soil samplers which require driving a second set of tools back down the probe hole in order to deliver the grout mix.

Monitoring Well Installation

An expendable cutting shoe enables the operator to install a Geoprobe® prepacked screen monitoring well through the outer casing of the DT325 Dual Tube System. After the collection of continuous soil cores to the desired depth, prepacked screens can be inserted to the bottom of the outer casing on the leading end of a PVC riser string. The well is finished, complete with grout barrier, bentonite well seal, and a high-solids bentonite slurry/neat cement grout, during retrieval of the outer casing.

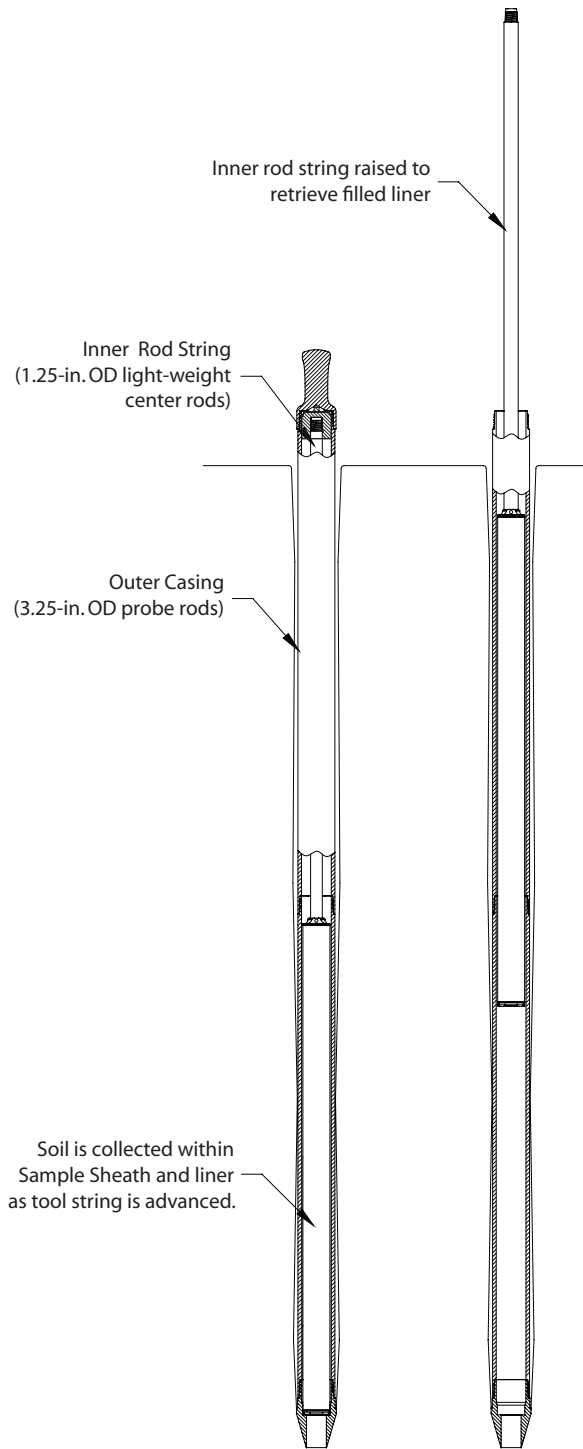

Figure 2.1
Outer casing driven with sample sheath and liner.

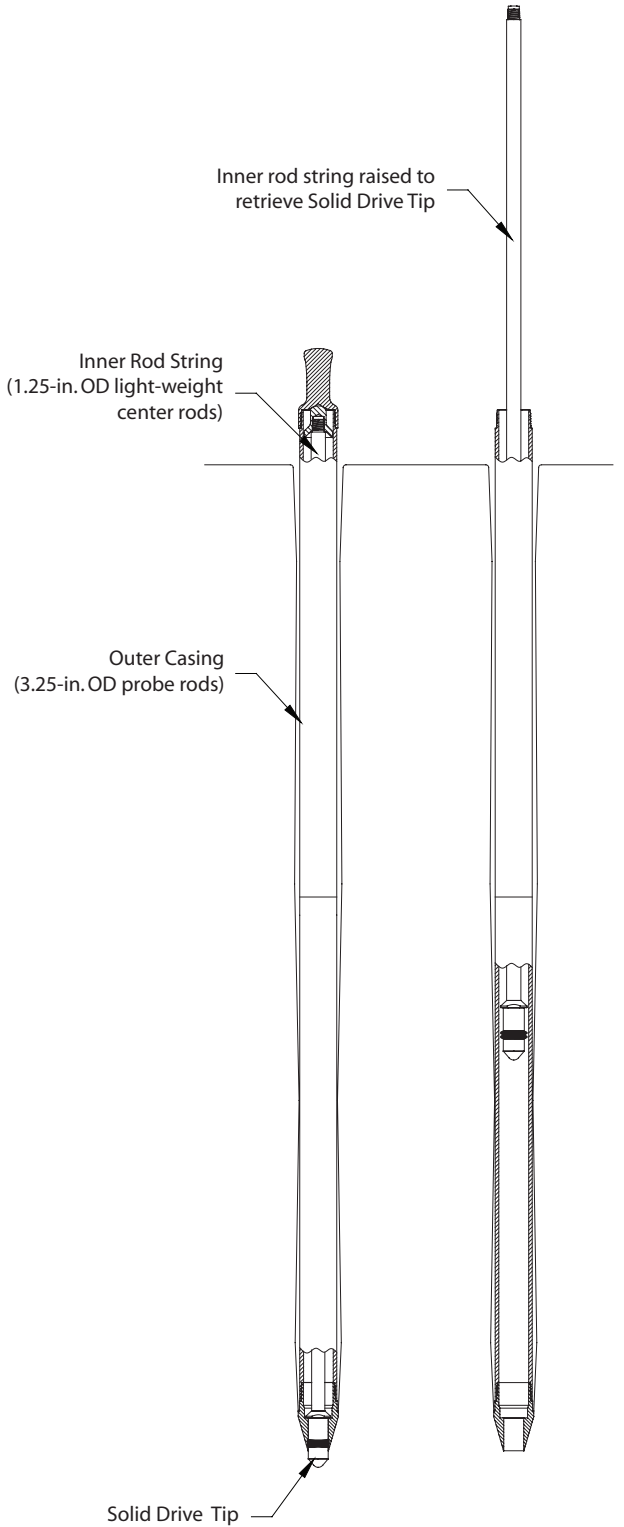

Figure 2.2
Outer casing driven with solid drive tip.

3.0 Tools and Equipment

The following equipment is required to operate the DT325 Dual Tube Sampling System. Refer to Figure 3.1 for identification of the specified parts.

DT325 Sampler Parts*	Quantity	Part Number
DT325 Sheath Drive Head	-1	10212
DT325 Sample Sheath, 72-in. length.....	-1	26805
DT325 Sample Sheath, 60-in. length.....	-1	26719
DT325 Sample Sheath, 48-in. length.....	-1	27711
DT325 Sample Sheath, 1-m length	-1	27712
DT325 Centering Drive Cap, 1.25-in. rods	-1	12943
DT325 Buffering Centering Drive Cap, 1.25-in rods	-1	37708
DT325 Cutting Shoe, standard, 1.85-in. ID	-1	28508
DT325 Cutting Shoe, optional, 1.75-in. ID	-1	26720
DT325 Expendable Cutting Shoe Holder.....	-1	28339
DT325 Expendable Cutting Shoe, 1.75-in. ID.....	-1	28341
DT325 Solid Drive Tip, for standard (28508) cutting shoe	-1	28509
DT325 Solid Drive Tip, for optional cutting shoe (28341) and expendable cutting shoe (26720)	-1	27763
Replacement O-rings, for DT325 solid drive tips (28509 and 27763), pkg. of 25	Variable	13942
DT325 Liner Retainer.....	-1	26718
O-rings, for DT325 liner retainer (26718), pkg. of 25.....	Variable	28379
DT325 Liner Retainer, without O-ring groove	-1	39011
DT325 Liner Retainer Wrench	-1	27838

DT325 Liners and Accessories	Quantity	Part Number
DT325 Liner Spacer.....	Variable	29609
DT325 Liner Spacer Head.....	-1	29358
DT325 PVC Liner, 60-in. length, box of 43	Variable	DT3260K
DT325 PVC Liner, 48-in. length, box of 43	Variable	DT3248K
DT325 PVC Liner, 1-m length, box of 43	Variable	DT3239K
DT325 PVC Liner with Core Catcher, 60-in. length, box of 43.....	Variable	27813
DT325 PVC Liner with Core Catcher, 48-in. length, box of 43.....	Variable	27814
DT325 PVC Liner with Core Catcher, 1-m length, box of 43	Variable	27815
DT325 Vinyl End Caps, pkg. of 84 (42 pair).....	Variable	17762
DT325 Liner Cutter.....	-1	26155
Universal Liner Holder	-1	22734

Probe Rods and Accessories*	Quantity	Part Number
GH60 Threadless Drive Cap, 3.25-in. rods**	-1	9742
Pull Cap, 3.25-in. rods	-1	13257
Rod Grip Handle, GH60 Hammer, 3.25-in. rods	-1	9757
Probe Rod, 3.25-in. OD x 60-in. length.....	Variable	9040
Probe Rod, 3.25-in. OD x 48-in. length.....	Variable	10594
Probe Rod, 3.25-in. OD x 1-m length.....	Variable	13925
Replacement O-rings, for 3.25-in. probe rods, pkg. of 25.....	Variable	9960
Pull Cap, 1.25-in. rods	-1	AT1204
Rod Grip Handle, GH60 Hammer, 1.5-in. and 1.25-in. rods.....	-1	15554
Light-Weight Center Rod, 1.25-in. OD x 60-in. Length***	Variable	27600
Light-Weight Center Rod, 1.25-in. OD x 48-in. Length***	Variable	21900
Light-Weight Center Rod, 1.25-in. OD x 1-meter Length***	Variable	32318
1.25-inch Leaf Puller	-1	31499
Adjustable Rod Clamp.....	-1	27216

Optional Accessories	Quantity	Part Number
DT325 Adapter for Hydraulic Liner Extruder	-1	24959
DT325 Plunger for Hydraulic Liner Extruder.....	-1	23977
Rod Wiper Donuts, 3.25-in. Rods.....	-1	27194
Rod Wiper Weldment	-1	23633

* Select DT325 Sample Sheath and liner lengths to match length of probe rods.

** A 3.25-inch probe rod drive cap is also available for use with GH40 Series hammers.

*** 1.25-inch OD probe rods may be substituted for Light-Weight Center Rods.

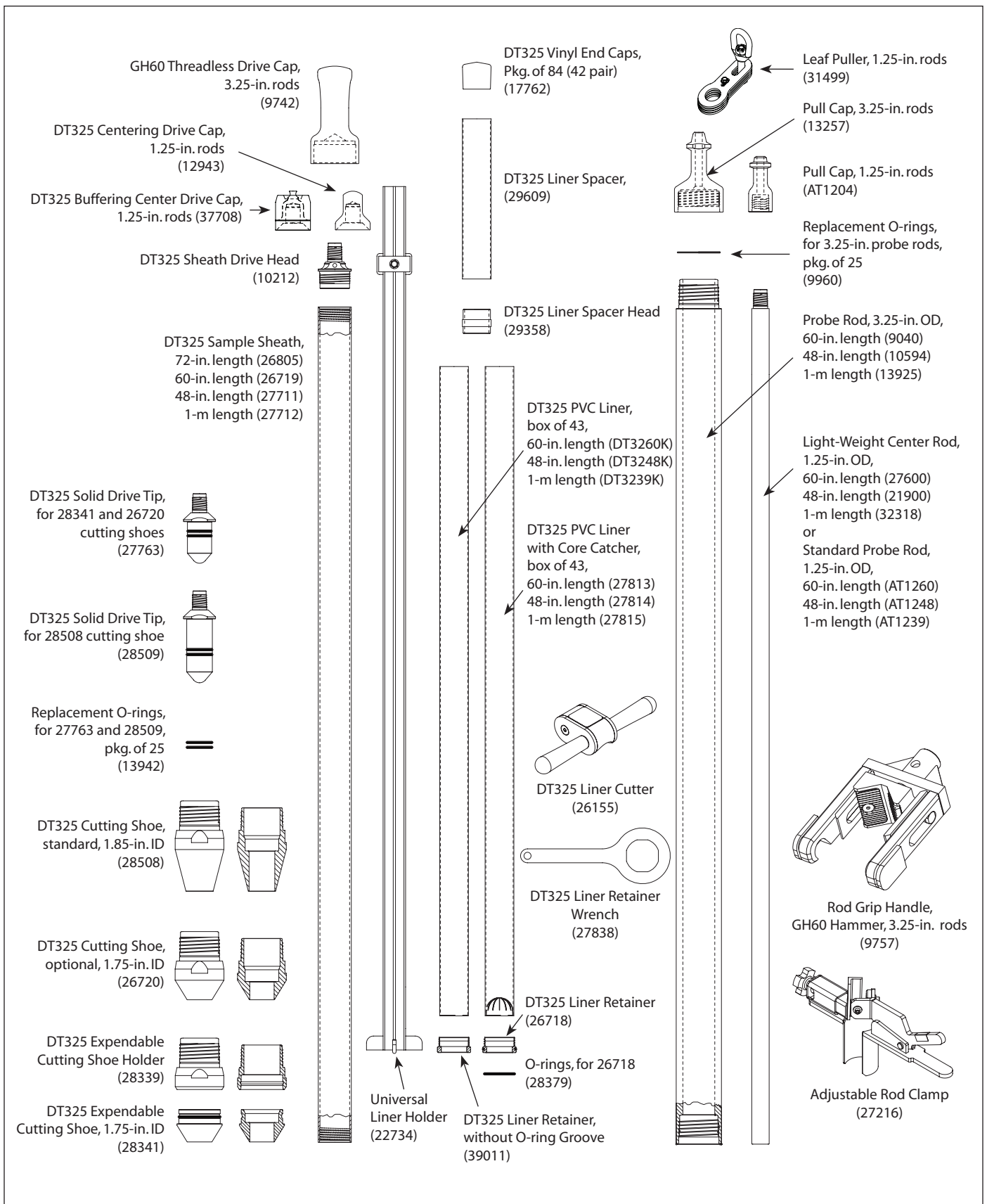

Figure 3.1
DT325 parts and accessories.

3.1 Tool Options

This section identifies the specific tool options available for use with the DT325 Dual Tube System. Refer to Figure 3.1 for illustrations of the specified parts.

Probe Rods

Standard Geoprobe® 3.25-inch (83-mm) OD probe rods are utilized for the outer casing of the DT325 Sampling System. Nominal rod lengths include 1 meter, 48 inches, and 60 inches. The specific length of rods may be selected by the operator and will determine the length of tooling for the rest of the DT325 system.

1.25-inch Light-Weight Center Rods

1.25-inch Light-weight center rods (1.25-inch / 32-mm OD) are recommended for the inner rod string of the DT325 system when utilizing an outer casing of 48- or 60-inch long rods. Choose the light-weight rod length that matches the length of rods used for the outer casing (48-inch light-weight rods with 48-inch outer casing, etc.).

A weight reduction of up to 64% is provided by the 1.25-inch light-weight center rods over standard 1.25-inch probe rods. As a result, considerably less energy is expended when retrieving the light-weight center rods from within the outer casing during operation of the DT325 Dual Tube System.

Sample Sheaths

A steel sample sheath supports the weight of the inner rods to protect the sample liner from damage while advancing the DT325 tool string. The liner is placed within the sheath and secured with a drive head at the top of the sheath and a liner retainer at the bottom. The assembled sheath with liner is inserted to the bottom of the outer casing on the leading end of the inner rod string (light-weight rods). After advancing the entire tool string one sample interval, the inner rods and sample sheath are retrieved to recover the soil core.

Sample sheaths are available in nominal lengths of 1 meter, 48 inches, 60 inches, and 72 inches. Sample sheath length is generally matched to the length of the probe rods selected for the outer casing. However, a DT325 Liner Spacer (29609) and DT325 Liner Spacer Head (29358) allow use of 48-inch liners with a 60-inch Sample Sheath (26719) and 60-inch liners with a 72-inch Sample Sheath (26805).

Sample Liners

Sample liners are made of a heavy-duty clear PVC for convenient inspection of the soil sample. Liners are available either as a simple, open tube or with an integral core catcher. Utilize the core catcher liners when sampling flowing sands, noncohesive soils, extremely dry soils, or any other materials that fall from the liner during retrieval.

Nominal liner lengths include 1 meter, 48 inches, and 60 inches with an OD of 2.1 inches (53 mm). Under “normal” sampling conditions, liner length should correspond to the length of probe rods used for the outer casing. Certain sampling conditions can cause over-filled liners which may lead to problems removing the liner and soil core from the sample sheath. For these special conditions, utilize a Liner Spacer (29609) and DT325 Liner Spacer Head (29358) to provide additional room above the liner for the excess soil (Fig. 3.2). The liner spacer and liner spacer head must be used with either a 48-inch liner in a 60-inch Sample Sheath (26719) or a 60-inch liner in a 72-inch Sampler Sheath (26805). With the tool string only advanced the length of the liner, the liner spacer remains free to accept excess soil that may otherwise overflow the liner.

Cutting Shoes

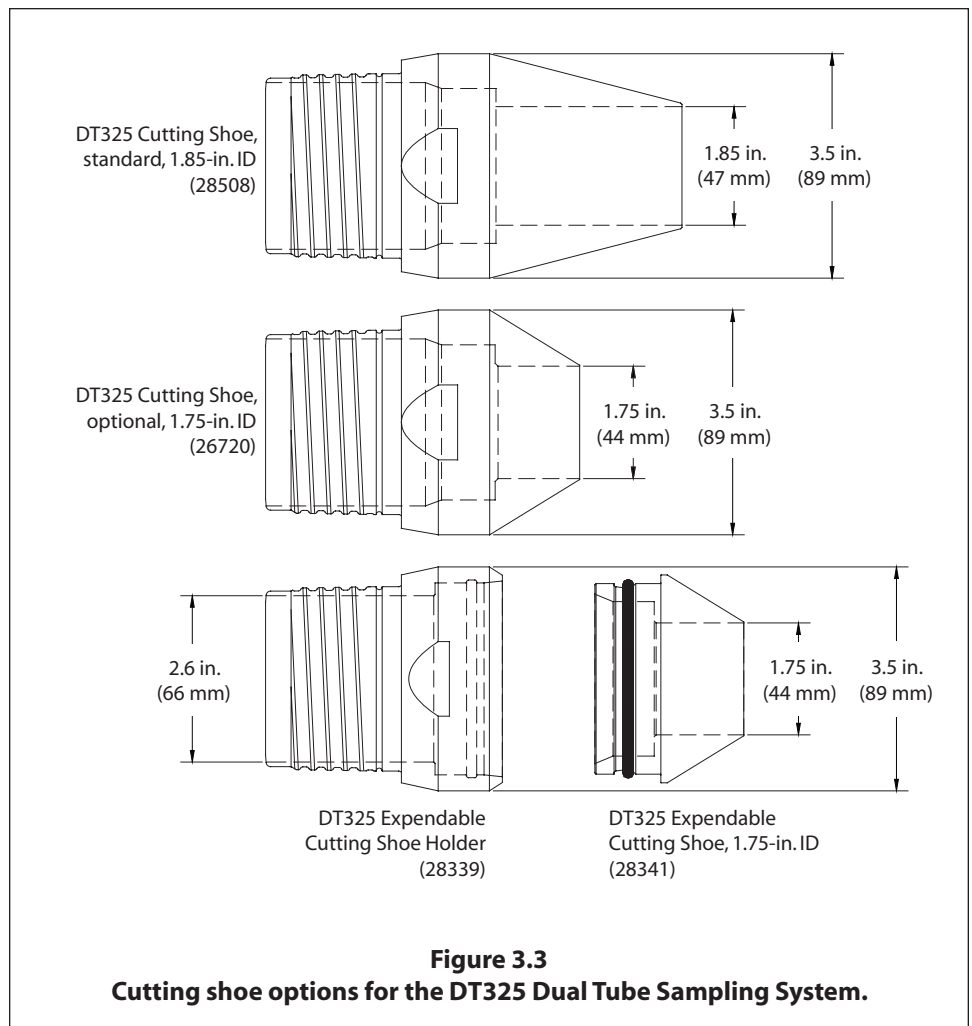
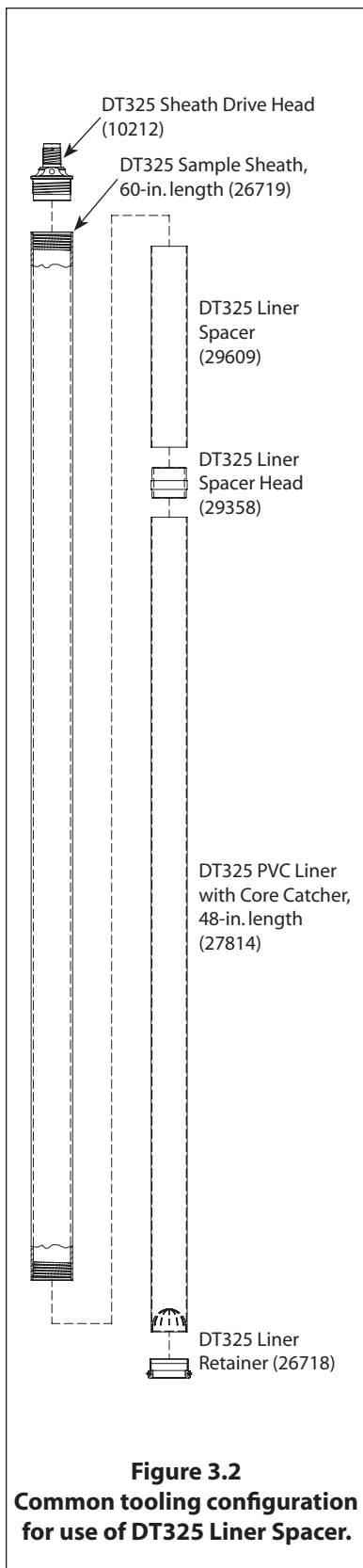

Three cutting shoes are available for use with the DT325 Dual Tube System (Fig. 3.3). The DT325 Standard Cutting Shoe (28508) and DT325 Optional Cutting Shoe (26720) thread into the leading end of the 3.25-inch probe rods and are recovered after sampling. Dimensions for the standard cutting shoe are 1.85 inches (47 mm) ID and 3.5 inches (89 mm) OD. The optional cutting shoe also has an OD of 3.5 inches (89 mm), but the ID is only 1.75 inches (44 mm). The standard cutting shoe is ideal for sampling plastic clays and saturated sands while the optional cutting shoe is designed for use in formations where a smaller-diameter soil core is beneficial to sample recovery.

The DT325 sampling system may also employ an expendable cutting shoe (Fig. 3.3). In this arrangement, a DT325 Expendable Cutting Shoe Holder (28339) is threaded into the leading end of the outer casing. A DT325 Expendable Cutting Shoe (28341) is then inserted into the holder. Upon completion of soil sampling, the outer casing is withdrawn slightly. The expendable cutting shoe is knocked from the holder, leaving an open casing through which a prepacked screen monitoring well may be installed. Dimensions for the expendable cutting shoe are the same as the optional cutting shoe (ID = 1.75 in. (44 mm) and OD = 3.5 in. (89 mm)).

4.0 Operation

4.1 Decontamination

Before and after each use, thoroughly clean all parts of the soil sampling system according to project requirements. Parts should also be inspected for wear or damage at this time. During sampling, a clean new liner is used for each soil core.

4.2 Operational Overview

The DT325 Soil Sampling System is designed to collect continuous soil cores. Sampling may begin either from ground surface or a predetermined depth below ground. Once sampling begins, consecutive soil cores are removed as the outer casing is advanced to greater depths.

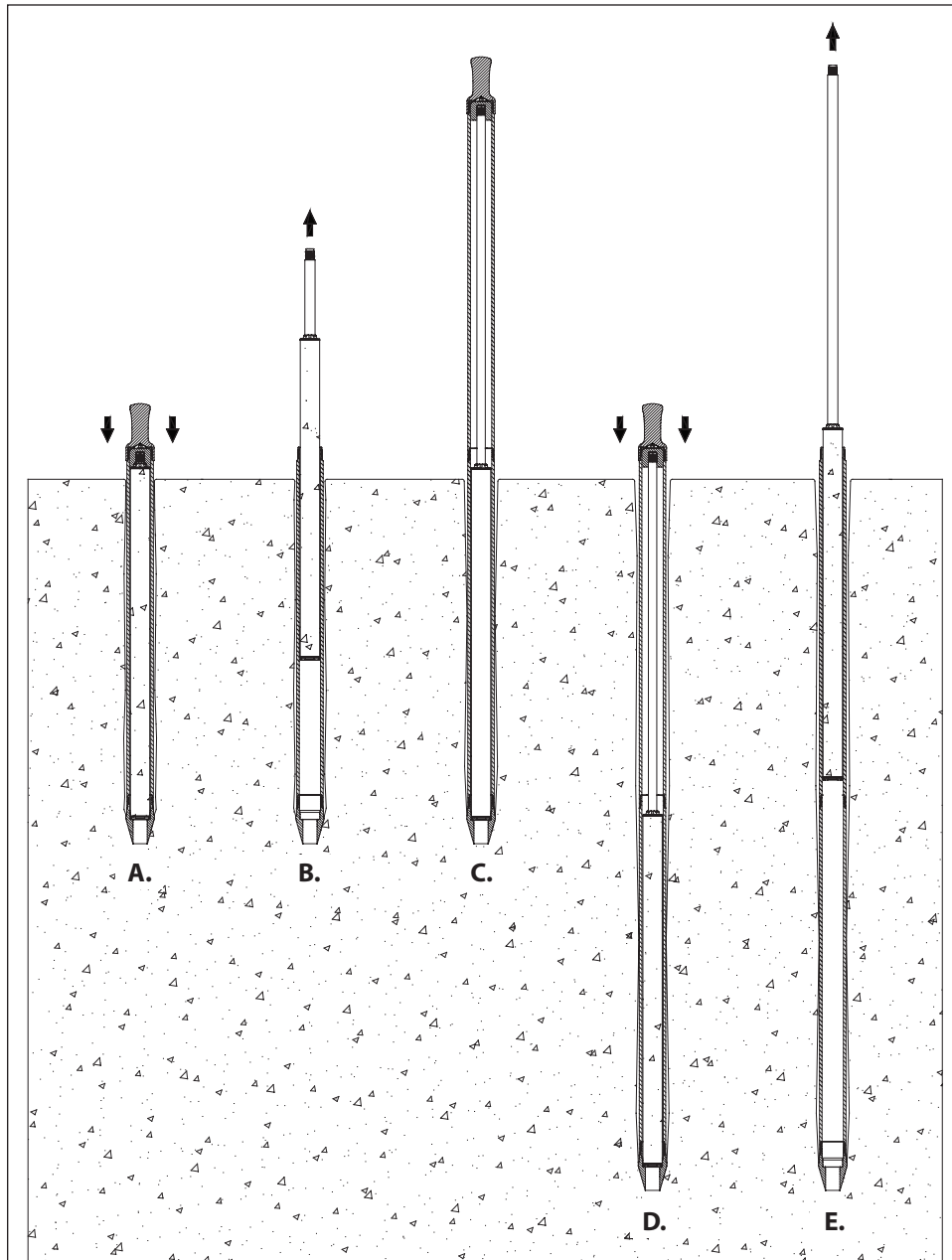

Figure 4.1
Continuous core sampling from ground surface with the DT325 system.

When sampling is to begin at the ground surface, the first soil core is generally collected using a liner with core catcher to maximize sample recovery (Fig. 4.1-A). This is especially true when the first core is composed of dry, loose soil. Upon retrieval of the first liner and soil core (Fig. 4.1-B), a new liner is loaded into the sample sheath and inserted to the bottom of the outer casing on the end of an inner rod. A section of outer casing is added to the tool string (Fig. 4.1-C) and the entire tool string is driven to fill the liner with soil (Fig. 4.1-D). The sample sheath and filled liner are removed from the outer casing to retrieve the second soil core (Fig. 4.1-E). A new liner is placed in the sample sheath and the process is repeated for the entire sampling interval.

When the sampling interval begins at some depth below ground surface, a DT325 Solid Drive Tip is installed in the outer casing and the entire assembly is driven from ground surface directly through undisturbed soil using the DT325 Centering Drive Cap (12943) (Fig. 4.2-A). This enables the operator to reach the top of the sampling interval without stopping to remove unwanted soil cores. Once the interval is reached, the solid drive tip is removed (Fig 4.2-B) and sampling continues using the Buffering Center Drive Cap (37708) as described in the preceding paragraphs (Fig. 4.2-C, Fig. 4.2-D, and Fig. 4.2-E).

Specific instructions for assembly and operation of the DT325 Sampling System are given in the following sections.

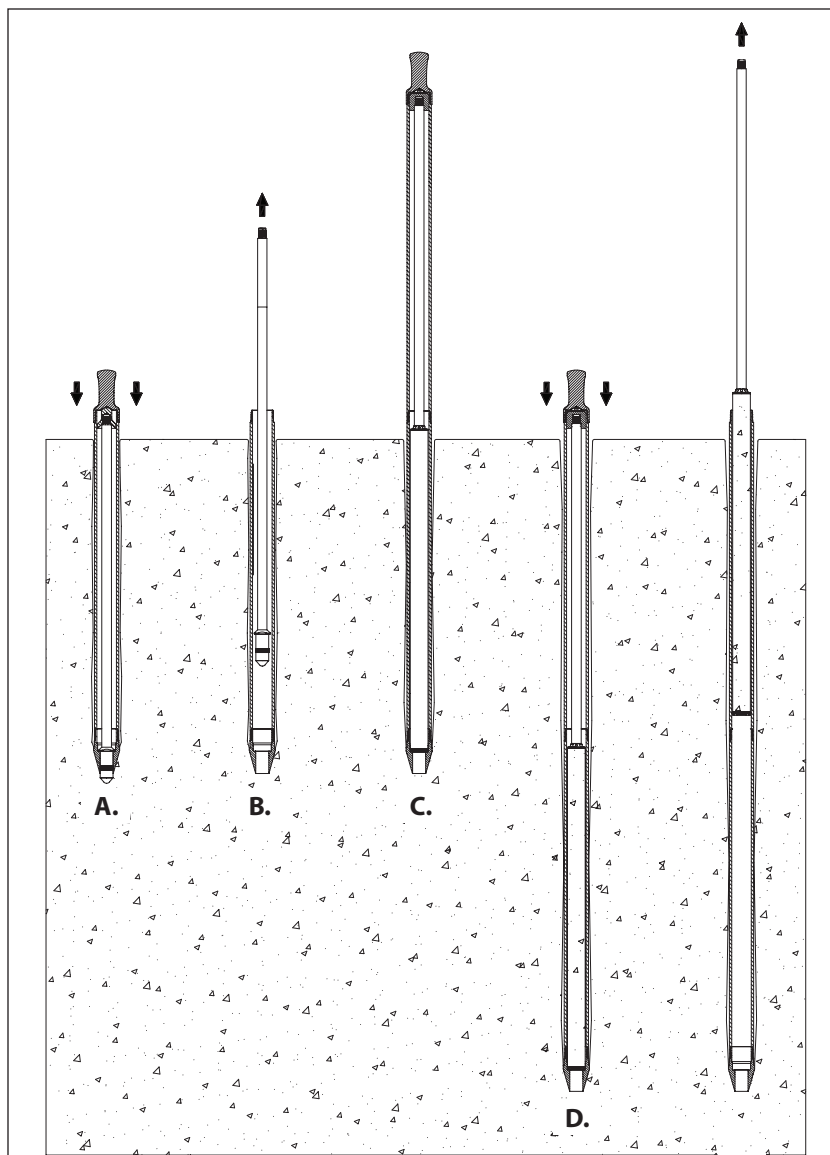

Figure 4.2
Using a solid drive tip to advance the DT325 outer casing through undisturbed soil before collecting soil cores.

4.3 Assembling and Driving the Outer Casing Using a DT325 Solid Drive Tip

A solid drive tip enables the operator to advance the outer casing to the bottom of a pre-cored hole or through undisturbed soil to reach the top of the sampling interval. The outer casing is assembled first, followed by the 1.25-in. light-weight center rod system with a solid drive tip. Step by step instructions are listed below.

1. When using a DT325 Standard (28508) or Optional (26720) Cutting Shoe, install an O-ring (9960) at the base of the threads as shown in Figure 4.3. If using an expendable cutting shoe, install an O-ring (9960) on the DT325 Expendable Cutting Shoe Holder (28339) and one o-ring (6834) on the DT325 Expendable Cutting Shoe (28341).
2. Thread the DT325 Cutting Shoe or DT325 Expendable Point Holder onto the leading end of a 3.25-inch OD Probe Rod. Completely tighten the cutting shoe or cutting shoe holder using a pipe wrench.
3. Install an O-ring (13942) in both grooves of the DT325 Solid Drive Point (27763 or 28509).
4. Thread the solid drive point into the female end of a 1.25-inch light-weight center rod.
5. Lubricate the O-rings on the solid drive point with a small amount of deionized water. Insert the point and probe rod into the outer casing until the point partially extends from the bottom of the cutting shoe.
6. Place a DT325 Centering Drive Cap (12943) on top of the 1.25-inch light-weight center rod and a GH60 Threadless Drive Cap (9742) onto the 3.25-inch probe rod (outer casing) as shown in Figure 4.5.
7. Raise the probe unit hammer assembly to its highest position by fully extending the probe cylinder.
8. Position the assembled outer casing section directly under the hammer with the cutting shoe centered between the toes of the probe foot. The assembled outer casing section should now be parallel to the probe derrick. Step back from the unit and visually check sampler alignment. A magnetic level can be placed on the assembly to check level.
9. Apply static weight and hammer percussion to advance the assembled outer casing until the drive head reaches the ground surface.

NOTE: Activate hammer percussion whenever collecting soil. Percussion helps shear the soil at the leading end of the sampler so that it moves into the sample tube for increased recovery.

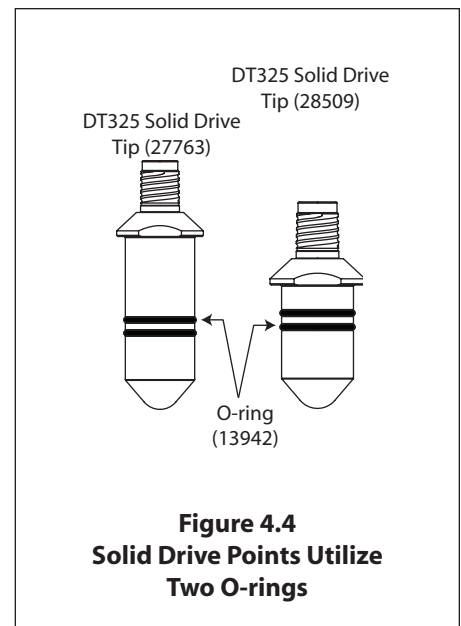
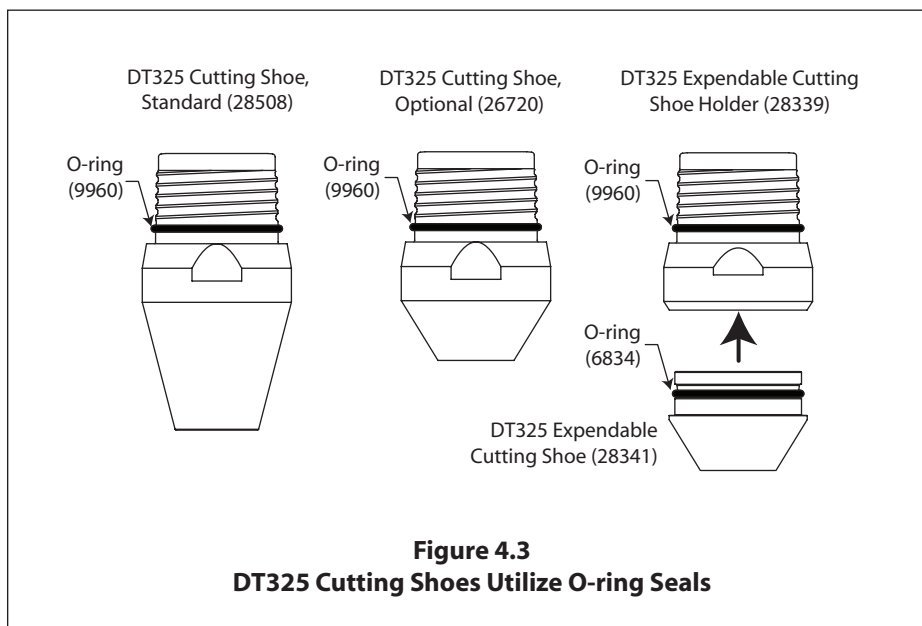

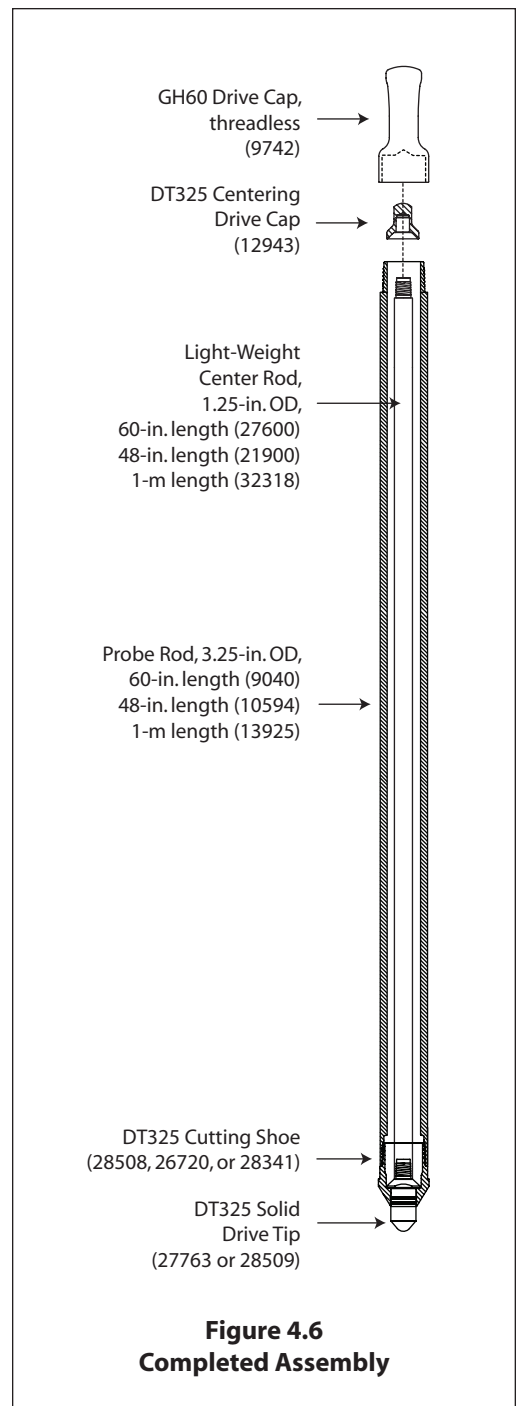
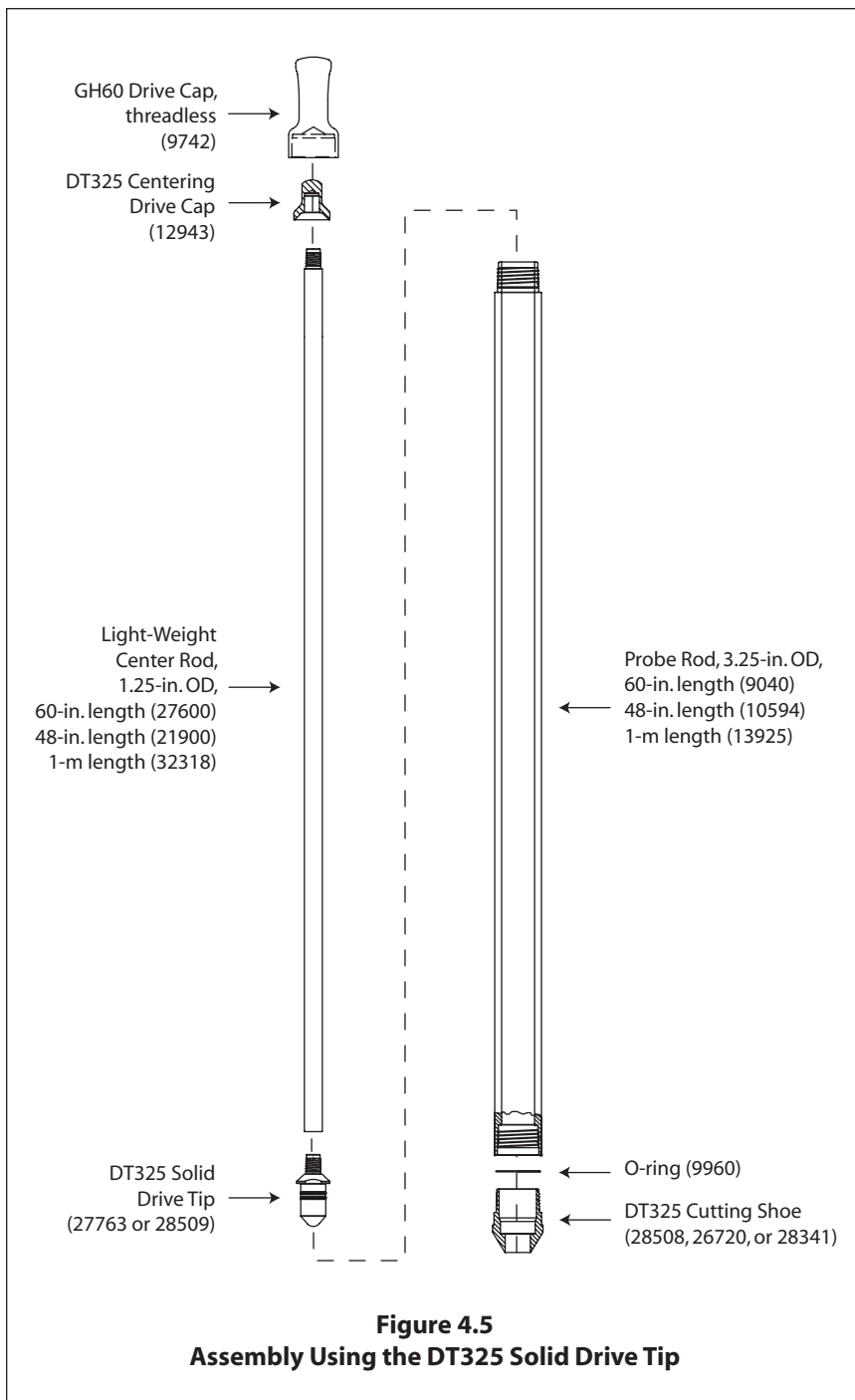

10. Raise the hammer assembly a few feet and retract the unit to provide access to the top of the outer casing assembly.
11. Remove the centering drive cap and 3.25-inch drive cap.
12. Add additional 1.25-inch light-weight center rods and 3.25-in. probe rods until the sampling interval is reached. At this point, the inner rods can be removed and an assembled sample sheath can be added (See Section 4.4)

4.4 Assembling the Sample Sheath

The sample sheath is used to support the weight of the 1.25-inch light-weight center rods and to protect the liner from damage while advancing the DT325 tool string. The process of assembling the sheath to collect soil samples is given below.

1. Place an O-ring onto the DT325 Liner Retainer. Note: No O-ring is needed for retainer 39011.
2. Slide the retainer ring onto the leading end of the liner. (Fig. 4.7).
3. Place the liner and retainer ring into either end of the sampler sheath (Fig. 4.8).
4. Thread the retainer ring onto the sample sheath. If the tools are clean, it should easily thread on easily by hand (Fig. 4.9).
5. On the opposite end of the sheath, thread on the DT325 Sheath Drive Head. The drive head will connect the sheath to the 1.25-inch light-weight center rods.



Figure 4.7. The retainer ring is placed on the end of the liner.



Figure 4.8. The liner and spacer ring are slid into the sample sheath.



Figure 4.9. Tighten the retainer ring by hand.

The sample sheath is now ready for soil core collection (Section 4.5).

4.5 Soil Core Collection

This section describes collection of continuous soil core samples from within the sealed outer casing of the DT325 Dual Tube Sampling System. The procedure is written for a sampling series that begins at the ground surface. Refer to Figure 4.10 for an illustration of the assembled sampler.

1. When using a DT325 Standard (28508) or Optional (26720) Cutting Shoe, install an O-ring (9960) at the base of the threads as shown in Figure 4.3. If using an expendable cutting shoe, install an O-ring (9960) on the DT325 Expendable Cutting Shoe Holder (28339) and one o-rings (6834) on the DT325 Expendable Cutting Shoe (28341).
2. Thread the DT325 Cutting Shoe or DT325 Expendable Point Holder onto the leading end of a 3.25-inch OD Probe Rod (Fig. 4.11). Completely tighten the cutting shoe or cutting shoe holder using a pipe wrench.
3. Insert the sample sheath assembly into the 3.25-inch OD probe rod.

4. Place a DT325 Buffering Centering Drive Cap (37708) on top of the DT325 Drive Head (Fig. 4.12) and a GH60 Threadless Drive Cap (9742) onto the 3.25-inch probe rod (outer casing, Fig. 4.13).
5. Raise the hydraulic hammer to its highest position by fully extending the probe cylinder.
6. Position the DT325 Sampler directly under the hammer with the cutting shoe centered between the toes of the probe foot (Fig. 4.14). The sampler should now be parallel to the probe derrick. Step back from the unit and visually check sampler alignment. A magnetic level can be placed on the assembly to check level.
7. Apply static weight and hammer percussion to advance the sampler unit until the drive head reaches the ground surface.

NOTE: Activate hammer percussion whenever collecting soil. Percussion helps shear the soil at the leading end of the sampler so that it moves into the sample tube for increased recovery.

8. Raise the hammer assembly a few feet and retract the unit to provide access to the top of the sampler.
9. Remove the drive cap and thread an additional 1.25-inch light-weight center rod onto the center string. Place the adjustable rod clamp on the top of the 3.25-inch rods to keep the center rods from falling when they are removed (Fig. 4.15).
10. Pull up the 1.25-inch light-weight center rod string along with the sample tube (Fig. 4.16). When available, the 1.25-in. Leaf Puller can be used with overhead winch.

To sample consecutive soil cores, advance a clean sample sheath and liner down the previously opened hole to the top of the next sampling interval. Add 1.25-inch light-weight center rods as the sample sheath is lowered into the opened hole. An additional 1.25-inch light-weight center rod and 3.25-inch probe rod should be added. Drive the tool string the length of the sampler to collect the next soil core. Proceed to Section 4.6 for instructions on recovering the soil core from the sample sheath.

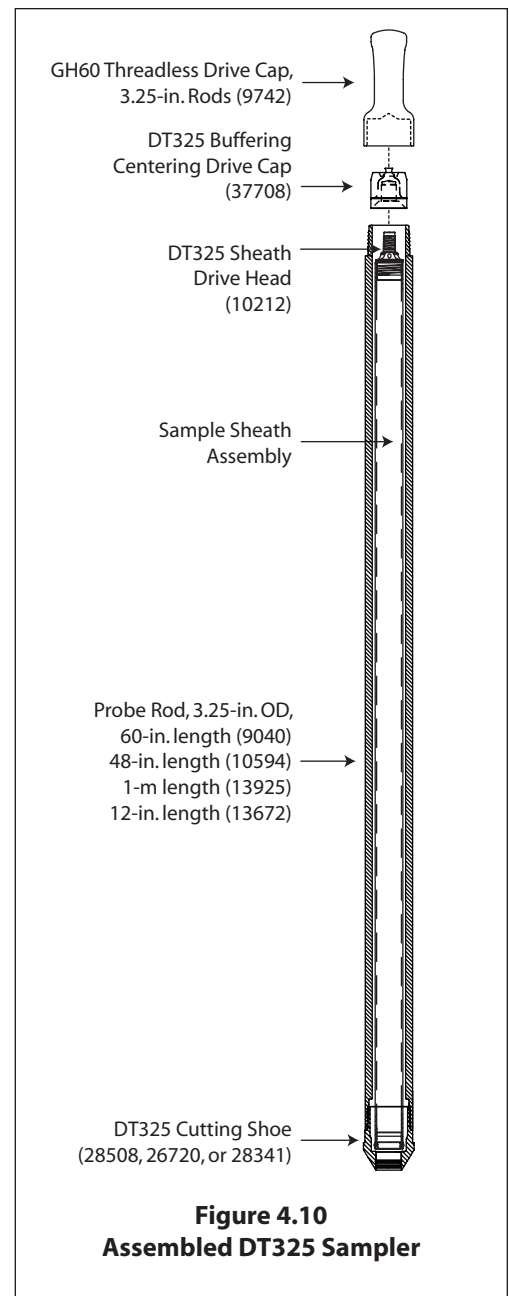

Figure 4.10
Assembled DT325 Sampler



Figure 4.11. The cutting shoe is threaded onto the 3.25-inch probe rod.



Figure 4.12. A DT325 Buffering Centering Drive Cap (37708) is placed on the DT325 Drive Head.



Figure 4.13. Place the threadless drive cap on the 3.25-inch probe rod.



Figure 4.14. The probe rod should be centered between the toes of the probe foot.



Figure 4.15. The adjustable rod clamp can be used when retrieving the sample.



Figure 4.16. The 1.25-inch light-weight center rods are pulled along with the sample tube.

4.6 Removing Filled Liner from the Sample Sheath

Place the sample tube into the vise. The liner retainer wrench can be used to remove the DT325 Liner Retainer and liner from the sample sheath. If possible, the retainer can be removed by hand (Fig. 4.17). The wrench can be used to gently knock off the retainer if necessary (Fig. 4.17). With the retainer removed, the liner and core can be withdrawn from the sample tube. A Hydraulic Liner Extruder is also available for mounting on your machine to remove liners (Fig. 4.19).



Figure 4.17. The retainer is removed from the sheath, either by hand or with the retainer wrench. Gently tap the retainer with the wrench to remove it from the liner.



Figure 4.18. The Hydraulic Liner Extruder helps remove the liner.

4.7 Removing a Section of Liner with a DT325 Liner Cutter

The liner and core can be placed on the Universal Liner Holder. Use the DT325 Liner Cutter to safely expose the sample. Begin the cut at the opposite end of the core catcher (Fig. 4.19). It is a little thinner plastic, which makes it easier to begin the cut. Using both hands, smoothly pull the cutter through the liner. The slit liner can be removed and the core is exposed (Fig. 4.20).



Figure 4.19. The DT325 Liner Cutter is used to safely make a longitudinal cut on the sample.



Figure 4.20. The core is exposed by the DT325 Liner Cutter.

4.8 Dual Tube Soil Sampling Tips

Saturated sands are the most difficult formations to sample with the DT325 system. Saturated conditions place positive pressure on the soil outside of the outer casing. When sampling in noncohesive formations (e.g. sands) below the water table, it may be necessary to add water to the outer casing to prevent formation heave. Adding water to the probe rods puts a positive head on the system and may keep formation material from flowing into the rods as the liner and soil sample are retracted. If a small amount of formation material is still drawn into the outer casing as the soil core is retrieved, the material may be displaced by slightly raising the outer casing while lowering the next new liner to depth. Water must be maintained within the outer casing during this process to overcome the hydraulic head imparted by the formation fluid. When retrieving, pull back the sample slowly.

DT325 core catcher liners will help considerably with sample recovery in non-cohesive soils and other materials that do not fill the liner diameter. Core catcher liners are not recommended for cohesive or extruding soils as the core catchers may actually inhibit soil movement into the liner. Also, using a shorter sample interval may improve sample recovery by minimizing wall friction as the material is sampled.

Certain soils have a tendency to exhibit plastic flow or extrusion characteristics. Allowing additional space for these materials will increase the speed of sampling because less time is spent cleaning overfilled sample sheaths. This will also yield a more representative sample. Using a sheath that is a foot or two longer than the sampling interval or using a shorter sample interval (under driving) can create a buffer zone. The DT325 Liner Spacer and Spacer Head were designed for these situations.

Some clay materials will extrude during sampling. Under these conditions, using a shorter sample interval (24-inch liners) may improve sample recovery by minimizing the wall friction as the material is sampled.

It is recommended that an O-ring be used on the liner retainer when sampling in clays. If an O-ring is not used, clay may build up between the sample sheath and the outer casing. It is not necessary to use retainer o-rings in saturated sands and anytime water is present.

It may be helpful to mark the first 1.25-inch light-weight center rod attached to the sheath as an indicator that the sheath is next in line.

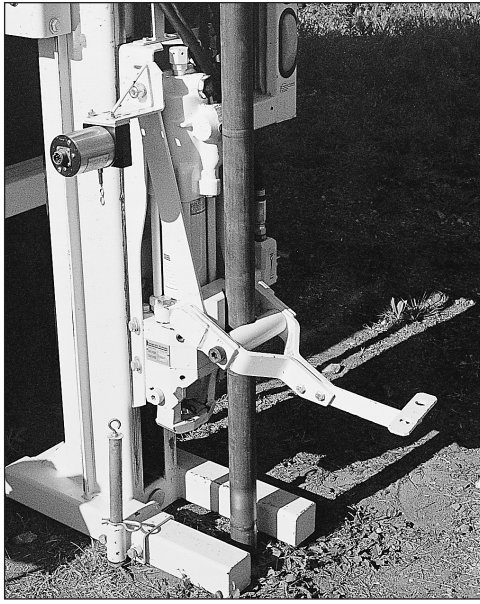

Figure 4.21. Outer casing may be retrieved with a pull cap or rod grip pull system if the probe hole is sealed with granular bentonite.



Figure 4.22. A grout machine and flexible tubing allow bottom-up grouting as the outer casing is retrieved.

4.9 Outer Casing Retrieval

The outer casing of the DT325 Dual Tube System may be retrieved in one of three ways:

1. Casing pulled then probe hole sealed from ground surface with granular bentonite.

The outer casing may be pulled from the ground with the probe machine and a Pull Cap (13257) or a Rod Grip Pull System (for GH40 Hammers [12235] or for GH60 Hammers [44688]) if the probe hole is to be sealed with granular bentonite from the ground surface (Fig. 4.21). This method is used for shallow probe holes in stable formations only. Such conditions allow the entire probe hole to be sealed with granular bentonite.

2. Casing pulled with probe hole sealed from bottom-up during retrieval.

Bottom-up grouting should be performed during casing retrieval in unstable formations where side slough is probable. Such conditions create void spaces in the probe hole if granular bentonite is installed from the ground surface. (Fig. 4.22)

3. Casing pulled with Geoprobe Prepacked Screen Well installed during retrieval.

The final option is to install a 2.5-inch OD Geoprobe® Prepacked Screen Monitoring Well in the probe hole during retrieval of the outer casing. A DT325 Expendable Cutting Shoe Holder (28339) and a DT325 Expendable Cutting Shoe (28341) allow the operator to collect continuous soil cores as the outer casing is driven to depth.

When sampling is complete, the outer rods are raised a few inches, and the expendable cutting shoe is deployed from the holder. This leaves an open casing through which a set of prepacked screens is lowered on the leading end of a PVC riser string. The well is finished, complete with grout barrier, bentonite well seal, and a high-solids bentonite slurry/neat cement grout, during retrieval of the outer casing.



Figure 4.23. Geoprobe® prepacked screens may be installed through the outer casing when an expendable cutting shoe is used.

Refer to Geoprobe® 1.0-in. x 2.5-in. OD and 1.5-in. x 2.5-in. OD Prepacked Screen Monitoring Wells Standard Operating Procedure (Geoprobe® Technical Bulletin No. 992500) for specific information on well installation.

5.0 References

Geoprobe Systems®, 2003. *Tools Catalog, V.6.*

Geoprobe Systems®, 2005. *Standard Operating Procedure. Geoprobe® Pneumatic Slug Test Kit. Technical Bulletin No. 19344.*

Geoprobe Systems®, 2010. *Standard Operating Procedure. 1.0-in. x 2.5-in. OD and 1.5-in. x 2.5-in. OD Prepacked Screen Monitoring Wells. Geoprobe® Technical Bulletin No. 992500.*

Equipment and tool specifications, including weights, dimensions, materials, and operating specifications included in this brochure are subject to change without notice. Where specifications are critical to your application, please consult Geoprobe Systems®.

Geoprobe Systems®

A DIVISION OF KEJR, INC.

Corporate Headquarters

1835 Wall Street • Salina, Kansas 67401
1-800-GEOPROBE (1-800-436-7762) • Fax (785) 825-2097
www.geoprobe.com



GET THE LATEST VERSION OF THIS DOCUMENT