

Geoprobe® 6712DT Drill Rig

Direct Push Rigs | 6712DT

Strong Direct Push Features in a Modular, Easy-to-Use Machine

Geoprobe® 6712DT modular drilling rig is perfect for small- to medium-sized direct push projects. It breaks into three components if necessary for easy transport to remote sites.

Modular Machine Design

- Can be assembled and disassembled in three parts
- Simple hydraulic design

Geoprobe® GH63 Series Percussion Hammer

- Modular percussion power cell technology
- Single speed bi-directional rotation

Rear Blade (Stabilization & Tool Transport)

Wireless & Tethered Remote Drive

Rotary Head (optional)

- Two-speed rotary head, 2,500 ft/lb (optional)
- Up to 150 rpm

Winch Mast

- Optional mast & winch system
- 2,500 lbf winch

Drill Mast

- 36,000 push
- 48,000 pull
- Sideshift (optional)

Controls

- Simple control panel design
- Manual controls provide tactile feel



WEIGHT & DIMENSIONS

Base Unit Weight: 6,250 lb. (2,835 kg.)

Includes drill mast side shift

Base Unit Weight: 6,030 lb. (2,735 kg.)

Does not include drill mast side shift

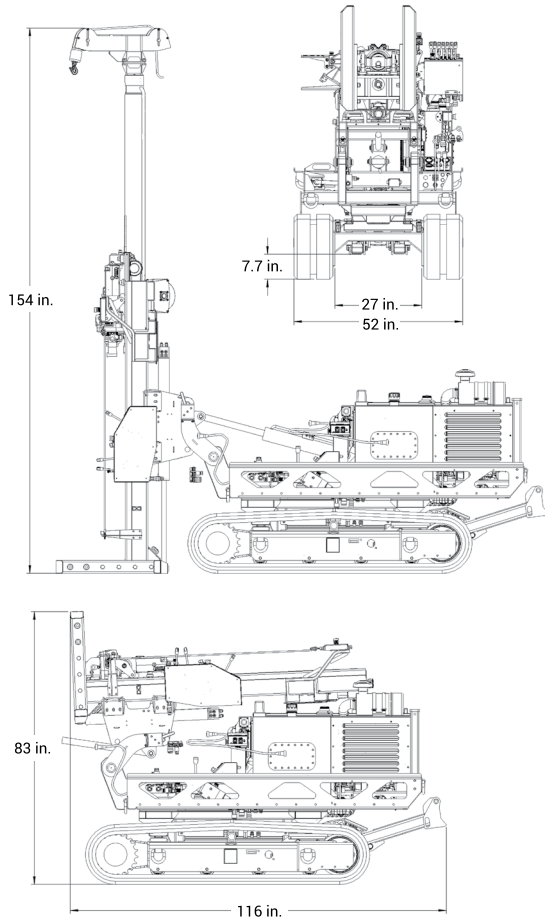

TOOLING

Typical Geoprobe® Tooling for the 6712DT

- 60-in. Direct Push Tooling
- Probe Rod Sizes: 3.75 in., 3.25 in., 2.25 in., 1.5 in., 1.25 in.*
- Macro Core® Soil Sampling (MC5, MC7)
- Dual Tube Soil Sampling (DT37, DT325, DT22)
- Groundwater Sampling (SP22, SP16)
- Prepacked Monitoring Well Installations (2.0 in., 1.5 in., 1.0 in., 0.75-in.)
- Direct Image® Tooling
- Interlocking Split Spoon Sampler

* Center Rod Use Only
Rig shown with optional features. Weights & dimensions subject to change without notice.



OPTIONS

Machine Modules

- Drill Mast
- CPT Mast
- Low Clearance Drill Mast with Sideshift
- Standard Undercarriage
- Lightweight Undercarriage

Rotary Head

- 2 Speed Rotary Head

Automatic Drop Hammer

- Automatic Drop Hammer, 140 lb.
- 170 lb. Expansion Kit
- Weight, 65 kg.

Mast / Winch

- Hydraulic Winch and Mast

Rotational Safety Cage

- Safety Cage

Water / Mud Pumps

- Moyno® 2L4 Pump Kit

Hydraulic Extruder

- 5 ft. Hydraulic Extruder Kit
- 5 ft. Hydraulic Extruder with Moyno® 2L4 Pump
- 3 in. Shelby Tube Cradle

Rod Racks

- Locking Side Mount Rod Rack
- Side Mount Rod Rack
- Side Rack Mount Blank

Toolboxes

- 48 in. Toolbox
- 53 in. Toolbox

Drop Rack

- Drop Rack System with Utility Rack
- Drop Rack System with Rod Rack
- Drop Rack with 50 gal. Pressure Washer
- Drop Rack System with 150 gal. Tank
- Water Transport System 25 gal.
- Yoke Vise and Mounting Bracket
- Rear Blade Forks (Pair)
- Rear Blade Hanger Blank

Additional Options

- CPT Valve Kit
- Cable Rod Rack
- LCD Display Heater Kit
- Drop Rack Suitcase Weight Assembly
- Wireless Radio Track Drive Option
- Field Service Kit
- Drop Rack Weight Assembly with Attachment Point



The track section of the 6712DT is lowered to a site on the mountainside to advance 4.25-in. hollow stem augers to install 2.0-in. monitoring wells.



Hydraulic Winch and Mast



2 Speed Rotary Head Attachment



Safety Cage



Extruder w/ 2L4 Mounting Kit



Locking Side Mount Rod Rack



Videos, Photos, Specifications, Resources

geoprobe.com/6712dt