

Success Stories to Spark Your Water Well, Geothermal, and Cathodic Protection Drilling Business

DYNAMIC DRILLER

SPRING 2023



DRILLMAX

DM650

Water Well Rig

DRILLMAX® DM650 offers options to outfit for air or mud with power to pull and push required for deeper drilling on large residential and light commercial water well or geothermal drilling jobs as well as farm irrigation water wells.

Geoprobe

PRODUCTS SPECIFICALLY
DESIGNED FOR WATER WELL
AND GEOTHERMAL
CONTRACTORS



DM650 Power to Pull, Push

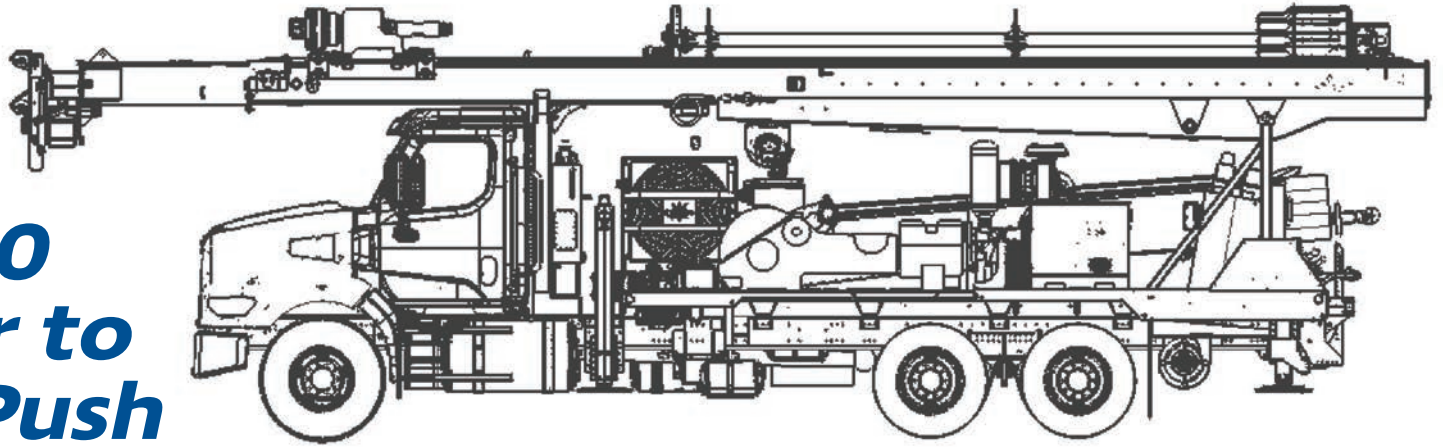

Growth east of home base in Burnet, Texas, has Robbie Barnard owner of **J&J WATER WELL & WINDMILL SERVICES** increasingly concerned whether he's equipped for success drilling the necessary 1,000-foot deep wells.

"My main concern is the rig I have now can't handle those depths, and I don't want to lose out on the business," Barnard said. "So the DM650 capabilities caught my eye and its similar operation to my current rig means I wouldn't have a huge learning curve."

Barnard perched on the DM650 at the National Ground Water Association (NGWA) show in Las Vegas last December for an hour taking in every inch of the new rig.

"What impressed me most was the engineers stuck to what has proven to work — manual controls," Barnard said. "Manual valves mean not much to go wrong and you have the ability to stay safe and confident it will work."

He appreciates the DM450 and DM650 share a similar simple control center with everything within reach in front of you.

"The controls on the helper side and extra rack for them to stand on is also an impressive addition," Barnard said.

He was also impressed by the attention to detail engineers placed on simplifying fieldwork.

"The way they built the breakout wrench caught my eye. They actually put handles on it. It's the little luxuries that make our day easier," Barnard said. "I looked at all the rigs there and the routing of the plumbing and hoses on the DM650 are very clean. They were in unison, mostly to always hidden, and were straight, narrow, and looked good."

Mark Kelly of **EMERALD COAST** in Alabama also appreciated the clean routing of hydraulic hoses when he saw it at the NGWA show.

"Man, I love the DM650. It looks like it's built well," Kelly said. "I appreciate the design of the new mud pump and the amount of power it has. It's a very nice, heavy-duty machine."

Kelly believes it would help him get a lot more of his 4- to 12-inch domestic farm and sprinkler pivot wells completed.

"It's much faster, heavier, and has more pull down," Kelly said. "I could do jobs a lot faster."

Other features catching drillers' eyes include:

- *Ample power, both on and off the road*
- *Increased speed and efficiency running multiple functions without losing hydraulic power*
- *Speed and labor savings of the rod carousel*

Mario D'Agostino admits he prefers a little extra when it comes to rig size for his New Jersey **D'AGOSTINO WELL & WATER SERVICES**. To him, the DM650 hits the mark.

"It looks well engineered with everything in the right spot," D'Agostino said. "It's probably bigger than I need, but if I bought a new rig, it would be what I want."

DM650 Features Suited for Drilling Bigger, Deeper

Drillers seeking rotary drilling options for larger, deeper wells in tough geologies choose the DRILLMAX® DM650 offering power of 28.5-foot stroke, 40,000 lb pullback, and 8,000 ft-lb torque. Backed by industry-leading service support, the rig offers additional advantages, including:

ROD CAROUSEL capable of backfeeding while running drill pipe frees helper to complete other site chores. Options available to accommodate preferred drill pipe size include:

- *Carry 12, 3.5-inch pipes for a total of 240 feet with ability to backfeed. The optional rod box carries an additional 18 pipes allowing you to carry a total of 600 feet on the rig with these two options.*
- *Carry 10, 4.5-inch pipes for a total of 200 feet with ability to backfeed. Optional rod box carries an additional 15 pipes allowing you to carry a total of 500 feet on the rig with these two options.*

TABLE ASSEMBLY hydraulically retracts and is easily

accessed from driller's platform providing up to a 24-inch opening and plenty of room to weld well casing. Various slip sizes available for drill pipe or casing.



NEW

DM650 Outfitted for Mud or Air Rotary

MUD DRILLING

Setup with 6X8 piston pump along with a 4X3 centrifugal pump with ability to run either pump independently or super-charge piston with the 4X3

AIR ROTARY

Down-the-hole hammer setup with up to 1070 CFM/350 PSI air compressor



drillmaxrigs.com/DM650



SCAN TO WATCH
DM650 Overview





NEW DM650

Large Residential • Light Commercial • Farm Irrigation
WATER WELL AND GEOTHERMAL DRILLING

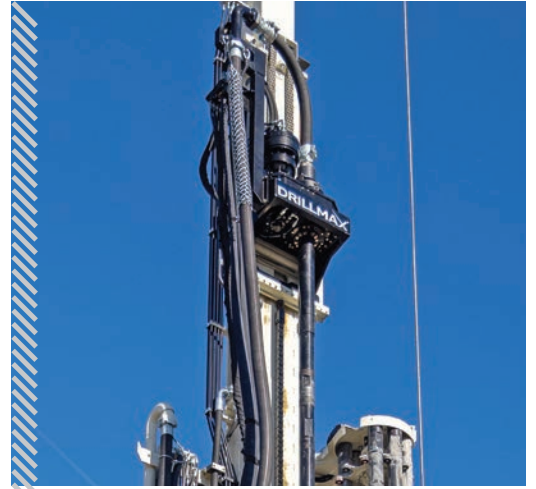

Rotary Head and Mast Make for Fast, Easy Drilling

Possessing power to reach depth with ability to support weight of steel casing, the DRILLMAX® DM650 is engineered to handle 24-inch wells. Top head and drill mast features contributing to its ability to quietly and smoothly drill deeper, bigger holes include:

SIDE SHIFT TOP HEAD BOTH DIRECTIONS with 39 inches of total travel to work with carousel and clear path along centerline.

2-SPEED ROTARY DRIVE provides 8,000 ft-lb rotational torque and 200 rpm with 3-inch spindle thru bore.

CARRIAGE ROLLERS for quiet, smooth head travel also mean:

- *simple adjustments*
- *fast and safe top head travel*
- *easy service to keep rig performing like new*

DUAL PIVOT JIB enables accessing both sides of the rig and includes:

- *two-speed primary winch, which swings and extends to the helper side; includes 17,500 or 12,000 lb options.*
- *secondary winch, which swings and extends to the driller side; secondary winch options include 1,800 lb sandline or a 5,000 lb tool handling winch.*



Request a Demo  785-825-1842



**SCAN TO WATCH
DM650 Features**



Travel to jobs in comfort cruising at 70 mph in DM250 without needing a class A/B CDL while having ample power to produce multiple wells per day.



DM250 Delivers Desired Efficiency

Growing up in a drilling family, Kyle Neuendorff began working for the family full-time at the age of 13, learning firsthand lessons on the inefficiencies associated with older equipment. So when he and his brother-in-law established **TEXAS SOUTHERN DRILLING** in 2019 their business objective was to become as efficient as possible drilling small residential 4-inch wells and small 6- to 8-inch irrigation wells.

"We wanted two guys in two trucks who can drive to a job and be able to complete a well without the need for other trucks or equipment," Neuendorff said. "Once you start moving three to four trucks to one job site, you lose about a half day, depending on how many people you have on payroll, for that one job. That's a lot of fuel and labor cutting into your profitability."

Having run rotary table rigs for the family business, when launching his business he sought a reliable, consistent, efficient rig. He bought a used top head drive, hydraulic drilling rig set up for 4.5-inch pipe, which he soon learned was overkill for their intended scope of work. He then began having electrical issues with the high-hour machine, and when it came time for a major part, he was told it would be a six-month wait.

"After all this happened, I told myself it was time to get some real machinery that was newer and updated with less hours," Neuendorff said. "I called up Donnie at DRILLMAX®, and he suggested I fly out to Salina [Kansas] to check out the facility and run a rig myself."

Neuendorff booked a flight and was able to view the DM450 and DM250 on his visit to the Geoprobe®/DRILLMAX® manufacturing headquarters. With his company targeting the smaller residential wells, the DM250 was a perfect match.

"When I flew out to Salina, seeing how organized the company was really sold me on going with them," Neuendorff said. "Talking to engineers who actually listened to me and wanted to implement my ideas was what made me order one."

What has surprised him most since running his new DM250 is the unmatched speed.

"From top head movement up and down, to adding rods from the carousel, to pulling rods back out of the hole — I can't say enough about the speed. And it's safe too," Neuendorff said. **"The other thing that surprised me is the capability to easily drill a 7-inch hole to 300 feet without issues. I couldn't be happier with the rig."**

According to him, the top head movement up and down means he can pull and fill 160 feet of pipe in the carousel in about five minutes. This capability along with the fuel efficiency top his list of favorite features.

"At high speed, the rig burns about eight gallons per hour. This is a game changer," Neuendorff said. "I can mud drill a 300-foot well and only use about 15-20 gallons of fuel."

When he reflects on the company's first rig, he realizes the efficiency and speed of the DM250. He also appreciates the DM250 being a comfortable, non-CDL-requiring chassis.

"The DM250 is on a cab chassis truck so I can safely drive 70 mph with cruise control, and being on such a small truck means no CDL," Neuendorff said. "My guys do not need CDLs to drive the DM250 or my support truck. If I really needed to, I could even run the DM250 by myself — although it's always better to have a second person on the job site for safety."

As desired, the DM250 has helped him solve his breakdown issues. Despite the minimized downtime, their customer wait lists were increasing to up to six months, and customers were hanging up and dialing the next water well company. So Neuendorff decided to add a second DM250.

"When you're efficient enough to drill one or two wells a day, you can keep your list pretty short thus earning more business, and you're able to charge a little more than the other guys," Neuendorff said. "We also do a lot of real estate contract jobs where they split land up into tracts and sell the land with power and water well. Those jobs I can usually complete two to three wells per day."

The increased efficiency has spurred company growth. They're up to 10 employees and three rigs running full time. He also feels like having the newer equipment provides a more professional appearance, and when kept clean, serves as great advertising going down the road. He appreciates the DRILLMAX® support and engineering system for helping them achieve the efficiency sought from their company's inception.

"When I had a few issues getting going, they answered the phone anytime and had me whatever I needed at my door the next day," Neuendorff said. **"I gave Donnie a list of what I wanted to see changed to make the DM250 even more efficient for what I was doing, and low and behold everything on my list was on the new DM250 at the National Groundwater Association show in Las Vegas. They listen to feedback and apply it to their product."**

Have a Rig Special Request?

Need a new rig but don't find a feature you're seeking? **GIVE US A CALL.**

Our team of engineers looks forward to collaborating with you. They continually work to make your drill rigs **FASTER, EASIER, and SAFER.**



785-825-1842

NEW

DM250

Residential Water Well and Geothermal Drilling

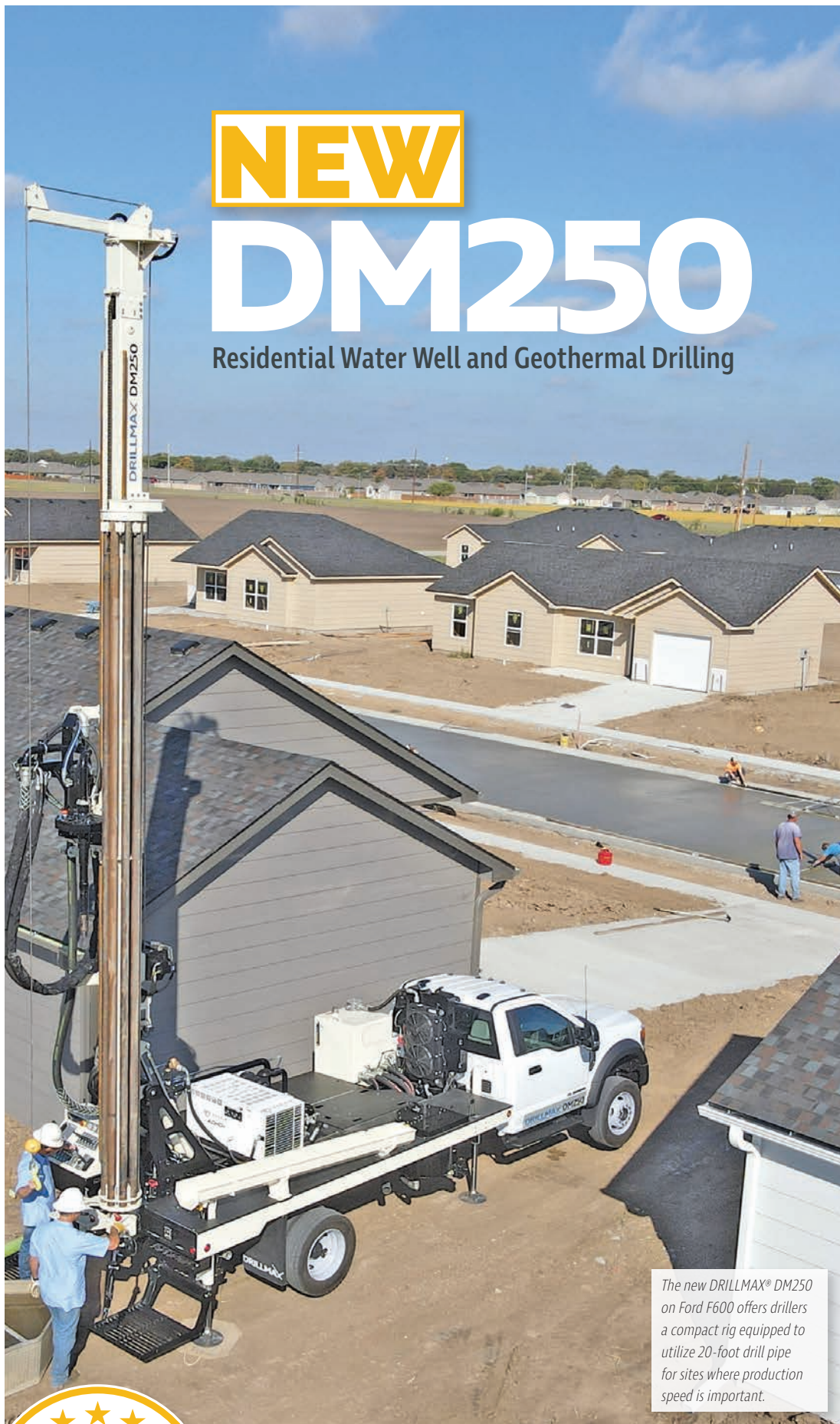

The new DRILLMAX® DM250 on Ford F600 offers drillers a compact rig equipped to utilize 20-foot drill pipe for sites where production speed is important.



DM250 on Ford F600 Incorporates Suggestions from Drillers in Field

Drillers across the country using the DM250 for their water well and geothermal work have been fueling our engineers with ideas and suggestions for improvements. In ongoing efforts to make drilling faster, easier, and safer the newest model DM250 on Ford F600 incorporates a number of those requests, including:

INCREASED REAR OUTRIGGER STROKE by 10 inches, providing more clearance to push and pull conductor pipe.

BETTER GROUND CLEARANCE provided by pads sitting 4.5-inches higher and split shaft sitting higher, improving ability to access job sites.

IMPROVED HYDRAULICS including:

- increased cooling capabilities.
- adjustable holdback improving control of down-the-hole hammer when driving casing and finer adjustments to see formation change when completing gravel pack wells.
- improved auxiliary hydraulics for increased flexibility when choosing rig options.

STANDARD HYDRAULIC TABLE



Faster, Quieter DM250 Hydraulic Table

- Bushing closest to mast incorporates hydraulic movement.
- Table slips to clamp and hold up-to 6-inch steel casing tight.
- Eliminates chattering pins in coarse sands and gravel for quieter job site.

Call about upgrade kits available for 2018 or newer rigs.



785-825-1842

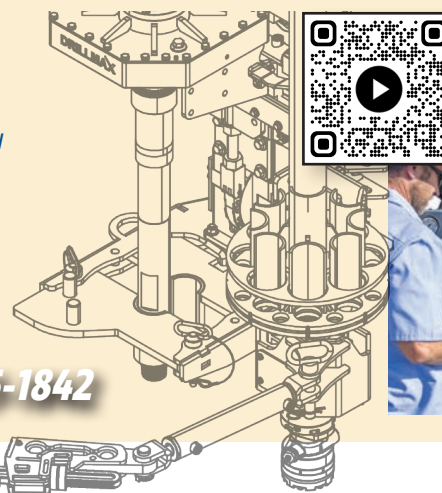

SCAN TO WATCH
DM250 Hydraulic Table





Speed and Safety Solidify Sustained Growth Spurt

Drilling since age 18, Paul Tyson decided to return to the industry when he and wife Michelle met and started their own water well installation and geotechnical drilling company in Florida.

"I was working in the insurance industry at the time and one of our coverages that could be purchased was contamination while in the hole. So I said to Paul, let's name our company 'DOWN THE HOLE TESTING AND DRILLING' and away we went," Michelle said.

Initially they would drill together. Now they have six employees and three rigs employed in their company built primarily by word-of-mouth and referrals.

"We have been very fortunate to have had enormous growth in the past three years," Michelle said. "The inception of the new rig has provided us capabilities to complete jobs much faster and more efficiently. It's been a great addition."

The equipment they had been running was aging and they desired a smaller machine with added safety and a longer stroke.

"It was the right move to make to keep us running as a well-oiled machine," Michelle said. "The DM250 really made it all come together to be more efficient and run smoother."

Having established a relationship with Donnie Wood while attending Florida Groundwater Association shows, they felt confident in what they learned from him regarding the DM250 capabilities related to their business needs.

"Our equipment didn't have the same capabilities as the DM250 with the carousel. The speed is just crazy compared to what we had to go through with our old equipment to drill a hard 130-foot hole," Paul said. "Our other two rigs were a 1977 and a 1987, so the mechanical speed and safety are night and day difference. Now we wonder how we ever did our job with the older rigs and equipment."

Paul appreciates the centrifugal pump moving mud fast and overall increased production rates.

"It's very efficient, so you're not waiting to clear cuttings. It just blows the cuttings right out of the hole," Paul said. "It has cut drilling time. Drilling a 160-foot well used to take three hours, now it only takes an hour."

He also appreciates the compact carrier making it easier to get in and out of jobs while also leading to fuel efficiency, which ultimately means cost savings.

"Being smaller means it's able to maneuver better between houses, and has a lower overhead clearance, so we don't have to cut as much stuff out of the way like low hanging branches," Paul said.

And they both praise the additional safety running the DM250.

"The safety of not having to handle the rods yourself means you don't have to worry as much about your fingers or hands being injured or getting in the way — the machine does it for you," Paul said.

Because of the added safety, they're not as reluctant as they were with their older equipment to have a new employee attempt to learn how to drill.

"Bringing on the next generation of drillers and teaching them how to drill with this rig makes the training process easier and better," Michelle said.

When an employee didn't show up for work one day, Michelle accompanied Paul on the job.

"I hesitated because I hadn't spent much time with the DM250 so I didn't know how much help I would be. He told me everything was so automated he could do it himself, he just needed me there for safety or if he needed mud," Michelle said. "I spent most of my time in the cab of the truck doing paperwork while he drilled the hole that day."

The capabilities of the DM250 have also led to them expanding their scope of work.

"We do a lot of 2- to 4-inch holes, but we're now doing more 6-inch holes because the DM250 can handle them," Michelle said. "We can now do that type of more profitable work and take on more of those types of projects. The ability to do more of those bigger jobs is a critical move to position for growth when you're more of a mom-and-pop shop like us."



Safe Carousel Option Promptly Pays for Itself

CHOOSE DEPENDABLE, EFFICIENT CAROUSEL OPTION TO SAFELY HANDLE DRILL PIPE AND SPEED OVERALL PRODUCTION.

- create opportunity to task helper with other site chores.
- safe rod lock requires rod to be rotated and moved vertically before it can exit the pod.
- rotate carousel to place indicator arrow between grooves on base, push handle, and lock carousel into position for safe travel while in transport position.
- mechanical alignment of top head with rods using indicator arrow and grooves on base eliminates need for electrical sensor that could malfunction.



SCAN TO WATCH
DM250 Overview



KS

DM250 commercial geothermal hole production matches rates of bigger rigs with advantage of fitting into urban job sites.

'Game Changer' for Geothermal



As ASSOCIATED DRILLING adapts to new ownership, they're also adapting to the smaller DM250. Calvin Piper now oversees technical work — pumps, water lines, out of water calls — while Kyler Erickson oversees drilling. This includes drilling for water well, geothermal, rock coring, monitoring wells, gas probes, post holes, electrical substations, and irrigation wells. The past few years the Kansas company has experienced an increase in water well and geothermal work.

"Many are tired of rural water bills going up and more people are wanting to be off the grid with their own source of water," Erickson said. "We have the DM250 running five days a week from one geothermal job to the next."

Their geothermal jobs are in Kansas City and Lawrence, Kansas, with houses stacked on top of each other, small yards, and established trees.

"We needed a rig sized to drill those residential geothermal systems. Jobs don't adapt to the equipment in the industry, the equipment has to adapt to the jobs," Erickson said. "We had to invest in a machine that could do the work and get into the jobs. We don't have problems getting into jobs with the DM250. Bonus is that it keeps right up with our bigger rigs."

For Erickson, the advantages of the DM250 include:

- **SIZE** — "It fits everywhere we go."
- **SPEED** — "I thought it would be slower than bigger rigs, but we haven't seen much change at all."
- **MAINTENANCE** — "Bigger rigs have more, bigger, more expensive parts. The DM250 maintenance has been simple and not much of it."
- **SIMPLICITY** — "It's easier to set up and be drilling in no time, which has increased our efficiency. We can back in and be up and drilling in less than 10 minutes."
- **FUEL EFFICIENCY** — "The DM250 saves us significantly on fuel consumption both traveling to the job site and while drilling compared to our larger rigs."

Typically they would use their bigger rigs on commercial geothermal jobs due to the required hole depth, but he recently put the DM250 on a commercial site drilling 75 percent of the 96 holes to 400 feet.

"It did great," Erickson said. "The speed of drilling 400-foot holes and tripping pipe meant it was taking maybe two hours per hole."

Since adding the DM250 to their fleet, word-of-mouth business on the geothermal side has increased with heating and air conditioning contractors calling them to come drill jobs.

"It helps them to sell a job when they can explain to a client that something just bigger than a dually truck will be doing the work," Erickson said. "So we've been getting more phone calls from different contractors and even the ones we've worked with for 20 years ask for the DM250 because it makes less mess and leaves less ruts."

The DM250 also makes their work smooth with no major breakdowns. When they have needed parts or service, the overall organization and efficiency of the Geoprobe®/DRILLMAX® Factory Service Center in Kansas has minimized downtime.

"The parts availability means I can get them the next day, there's no waiting two to three weeks for parts," Erickson said. "I scheduled the rig with service, drove it down, got it in, and headed home the next day."

Erickson also appreciates the open ears exhibited by the team of engineers, who he says are willing to pick up the phone.

"Engineering and service are always open to our suggestions. Some places see it as an insult when you offer a suggestion. It's not that way at DRILLMAX®," Erickson said. "They're always wanting to do better and want to know what they can improve on."

When other companies ask Erickson how their DM250 is doing, he lets them know it's a game changer on the geothermal side of the company.

"It gets into jobs much easier, is quicker to set up, and drills fast," Erickson said. "The DM250 can definitely compete with the larger rigs in the geothermal and shallow water well market."



SCAN TO WATCH

DM250 Customer Testimonials



- DOWN THE HOLE DRILLING
- ASSOCIATED DRILLING

Watch as Paul Tyson and Kyler Erickson describe their experiences using their DM250 on water well and geothermal jobs.

Rig Speed, Service Propel Production

A third-generation company begun by her grandfather Andy Kuka 60 years ago, Danielle Gambrel took over from her father Vince Kuka when he became ill. Completing residential wells and service in Florida as **SPRING HILL WELL DRILLING** for the last 45 years, their fleet consists of three drill rigs and two service trucks.

"We began the business using cable tool rigs. We got our first rotary drill 20 to 25 years ago," Gambrel said.

When it came time to add another rig, their success with a legacy DM250, along with ability to get parts next day, pushed them toward another DRILLMAX®.

"We liked the DM250 we already had and knew that answers to any questions or problems we had were readily available," Gambrel said. "We got the carousel on this one to make it easier for our older driller to run. It's cost efficient on fuel and easier for our guys to work with while service is right here."

As owner, she appreciates the fuel efficiency of the new DM250, completing three wells on half a tank of fuel compared to their legacy DM250 which uses up to a half a tank per well. As operator, Tony Eilers appreciates the ease and speed of the new DM250.

"I've run other rigs and this is my favorite machine so far. It's easy, quick. I've been in the industry 25 years — 20 in Florida — and it's the best rig I've ever run," Eilers said. "It's so fast and quick thanks to the top head speed, winch line speed, and carousel, which is a lot faster than the rod loader. For Florida drilling, going in and out of the hole is quicker and a lot less intense labor. You can basically run the machine yourself while the helper naps in the truck cab."

With the carousel adding to the ease and speed of operation, they've established a goal of three wells per day.

"My nickname is 'Two-fer Tony' because I get two wells done per day. We're working toward getting three done," Eilers said. "I've drilled 250-feet without any issues. I've only drilled with air compressor or foam. Not sure how deep I could go with the mud pump."

Gambrel believes they can achieve the goal of three wells per day.

"We can definitely accomplish more," she said. "We can schedule more work and get more done in a faster amount of time."

They also appreciate having support from the Geoprobe®/DRILLMAX® Southeast Service Center to help them meet their goals.



Nicknamed "Two-fer Tony," Tony Eilers sees potential of drilling three wells per day with their DM250.

"We can lean on Donnie, and the guys at the Southeast Service Center have been awesome — even if we have questions or need something for a competitor's rig," Gambrel said. "They're accommodating, on top of it, and get to it as soon as possible. We've had some work done on a rig, and they came to the job site to make sure everything was working correctly and we had everything we needed."

An active member of the Water Well Guys Facebook group, Eilers is often called to share his thoughts on the DM250.

"I tell them these machines are built right; you don't need a CDL. It's hard to find someone with a CDL today, but with the DM250 the helper can drive while I drive the service truck," Eilers said. "I've had no problems with the rig; it's been good to me."

INDUSTRY-LEADING SERVICE

Geoprobe®/DRILLMAX® industry-leading service has garnered praise from customers like Tony Eilers and others active on the Water Well Guys Facebook page (see photo at right). No matter where you're located across the country, we're just a phone call away to provide troubleshooting over the phone or activate a field team to help solve your service struggles. Breakdowns are never convenient, but you can depend on our fully trained and experienced service technicians to service, repair, and restore your drill rigs — no matter the brand. They're supported by our team of engineers committed to solving problems not just applying band-aids.



LEGACY RIGS
built BEFORE 2018

Todd Ewing
service technician
352-854-1566

RECENT RIGS
built AFTER 2018

Jason Lindenmuth
service technician
785-825-1842



Rod carousel on DM450 propels well production, driving casing from the surface and drilling out the well with air while parts in stock keeps everything running smoothly.

FL



Access to Service, Parts Minimizes Downtime

In business providing mainly residential and commercial water well drilling and pump service in Florida since 1997, **AFFORDABLE WELL DRILLING & SERVICE INC** has experienced significant growth the past five years.

"We've gone from running two cable tool rigs to four rotary rigs and two service trucks," Grady Christian, president, said. "We needed a new rig because we couldn't keep up with demand."

Proximity to the Geoprobe®/DRILLMAX® Southeast Service Center in Ocala, Florida, along with multiple decades working with Donnie Wood, DRILLMAX® sales representative, persuaded Christian to invest in a new DM450.

"We're now doing more work, producing more wells per day," Christian said. "The carousel holds 300 feet of 3-inch pipe, which really helps out. We always have two guys on the rig, but with the carousel the helper has more time to get other things done while the driller runs the rod."

They primarily drive casing from the surface then drill out the well with air. Recently service technicians from the Geoprobe®/DRILLMAX® Southeast Service Center came out to evaluate the air compressor performance.

"They did an adjustment on the air compressor and got it running really well," Christian said.

He depends on the Geoprobe®/DRILLMAX® Southeast Service Center for their efficient work and shelves stocked with parts.

"They get things fixed quickly. They keep a good parts selection so if the rig goes down, I call them and get parts sent right over so there's not as much downtime," Christian said. "I've ordered seal kits for winches, sliders for the derrick. Most every time they've had everything in stock."



Same Day Parts Shipping

Most replacement and critical parts are kept on the shelves. Call before 2 p.m. local time, we'll ship most parts same day.

DM450 Carousel Capable of Backfeeding Drill Pipe

CREATE OPPORTUNITY TO TASK HELPER WITH OTHER SITE CHORES WHEN YOU CHOOSE CAROUSEL OPTION.

- two safe and easy carousel options based on drill pipe preference — 3 or 3.5 inch — able to backfeed while running pipe.
- simple, durable air fork at top of carousel operated from control panel holds drill pipe in position (pictured above).
- pod for each pipe contains a cushion spring prohibiting pipe from slamming into pod, protecting pipe and creating a quieter job site.



SCAN TO WATCH
Tighten Spindle Bearings

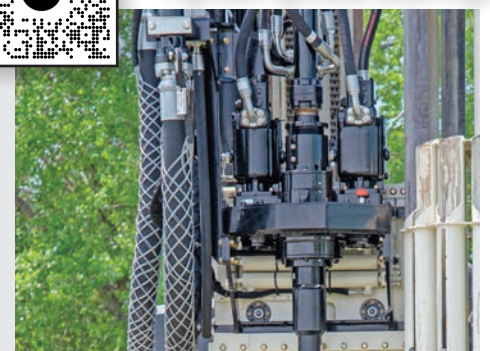

Efficient Rig, Solid Support

Running one legacy model DM450, family-owned **DICK JOYCE WELL DRILLING** found themselves looking for a solution to their lengthening list of work.

"We got into the market for another rig due to our extensive backlog," Ryan Hadden, operator, said. "We found ourselves months out for new well installs and began losing work due to the length of time our customers were forced to wait."

Hadden began in 2010 doing service, water filtrations, and a variety of things for the Florida company his grandfather started in 1969. He progressed to driller's helper a few years ago. When the company — owned by his mother and uncle since 2002 — purchased the new DM450 it became his first machine as driller.

"We can now service our customers quicker and keep up with growing demand," Hadden said. "There's a lot to be impressed by with the rig — power being one of them. Since we had a legacy DM450 for several years already, we had an idea of what to expect. However the performance I've gotten out of our casing driver with the new DM450 has been outstanding."

The rod carousel on the new DM450 has not only propelled production rates but also solved their problem of accessing small job sites.

"The top head travel is smooth and quick. Paired with the 15 rod carousel, we can trip in and out of the hole very quickly," Hadden said. "We can load all the materials on one truck by utilizing the rod box as casing storage and have enough deck space for a water tank for water injection. Therefore we no longer worry about a support vehicle being near."

The ability of the air on the new DM450 to drive pipe without slowing down means they're able to speed production and expand into new areas averaging 200- to 250-feet of casing.

"We drive our casing in and typically would need to drill ahead to set that much casing to rock. With the power of this machine, many times we are able to drive all of our casing," Hadden said. **"We are doing multiple wells in a day; we're also taking work in more challenging areas; and we're rewarded with still being able to finish those wells within a day's time."**

They also opted for a hydraulic welder on the rig, saving on fuel and hassle.

"Having the hydraulic welder and retractable reels has saved not only space and gas but also made setting up and tearing down quicker," Hadden said.

The efficiency of the carrier also contributes to fuel savings.

"I've drilled three wells and returned to the office on one 70-gallon tank of fuel," Hadden said.

For Hadden, the new DM450 is hands-down a reliable rig, worth every bit of money paid, and "comes from good people too."

"Everyone involved is focused on keeping you up and running. Whether you need a part or a technical question answered, you will receive support as fast as possible," Hadden said. **"When spending that amount of money, you're buying a piece of equipment but also the people who stand behind it. With DRILLMAX[®] you're definitely getting your money's worth in both aspects."**



DM450 rod carousel and hydraulic welder eliminates support truck while power to drive 10-inch steel casing creates ability to profitably drill in more challenging areas.

On-Board Hydraulic Welder Saves Time

SPEED PRODUCTION AND ELIMINATE BIGGER SUPPORT TRUCK WHEN CHOOSING ON-BOARD HYDRAULIC WELDER.

- mounted below deck conserving space while providing alternate generator source for other power tools like a grinder.
- runs off truck hydraulics eliminating hassle of carrying fuel for a gas generator.
- welding leads accessible on truck rather than strung out across job site.
- speeds process of set up and tear down while keeping everything dry.





Used Drilling Rigs

All Used Rigs Submit a Used Listing Contact Us

Welcome to the "Used Drill Rigs" section of the DRILLMAX[®] website. This is a free service that we offer for listing used drill rigs for sale and equipment. If you're in the used DRILLMAX[®] market, check the website often because our previously-owned machines move fast! No fees. No listing charges. By posting a used equipment summary and photos online, more DRILLMAX[®] customers can access the information quickly. We can also provide suggested trade-in values for your machines to help in the process. Listings will remain active for 180 days. DRILLMAX[®] reserves the right to not post any item(s) deemed not beneficial to the DRILLMAX[®] customer base and/or Team DRILLMAX[®] organization.

POST AND SELL YOUR UNDERUTILIZED DRILLING EQUIPMENT TO FREE UP CASH.

Search by Name Search

	Model: Canterra CT 350 Year: 1990 For Sale By: DRILLMAX [®]		Model: SIMCO 2800 Year: 2005 For Sale By: DRILLMAX [®]		Model: DRILLMAX [®] 2400 Year: 2011 For Sale By: DRILLMAX [®]
---	--	---	---	---	---

Used Rig Posting drillmaxrigs.com/USED



SCAN TO WATCH DM450 Overview



Spring Assisted Swivel Hoist Plugs Increase Safety

Leveraging experience in the geotechnical market developing spring assisted swivel lift caps to maintain winch line tension, tooling design engineers brought similar technology to the water well drilling industry with the spring assisted swivel hoist plug.

Utilizing 20-foot drill pipe with a standard hoist plug results in the pipe leaning and binding threads, requiring the operator to manage the winch tension. The spring assisted swivel hoist plug supports the weight of a drill rod, providing the correct winch line tension when threading tool joints, ultimately leading to a faster, easier, safer job.



"The spring and bearings eliminate the operator having to manage the winch line tension, allowing him to focus on his hands at the tool joint," Quinton Bogner, tooling design engineer, said. "The operator doesn't have to look away from his immediate surroundings to keep the drill rod aligned and the winch line properly tensioned, creating a safer working environment."

Vent holes in the spring assisted swivel hoist plug allow the drill string to drain fluid down hole as rods are removed versus spraying out of the tool joint when unthreading, which results in a tidier job site.

"This feature keeps the driller and his machine cleaner when on the job site," Bogner said.



Spring assisted swivel hoist plug



Additional Hoist Plug Styles and Sizes Now Available

SPRING ASSISTED SWIVEL HOIST PLUG in new sizes support the weight of a drill rod for faster, easier rod changing while it also:

- eliminates adjusting controls to maintain winch line tension
- minimizes wear on threads from binding
- lessens frustration and strain on operator
- keeps operator and job site cleaner

It takes the effort out of what the driller and helper have to do, making jobs easier and better. Anytime you buy a tool that makes life a little easier, it's a good value. Just makes work not so much work."

— Steve Simmons, owner, Roy Simmons & Son Well Drilling, Michigan

BACKLOADING HOIST PLUG

now available to use with DM450 and DM650 carousel when retrieving rod out of rod rack to backload carousel.

Backloading hoist plug



4.5-inch OD Drill Pipe Now Available

Engineered to withstand the bigger, deeper work performed by the NEW DM650, the NEW 4.5-inch OD DRILLMAX[®] drill pipe incorporates a high-strength, lightweight mid-tube between heat-treated, alloy steel ends. Wrench flats are extended to 6 inches for heavy-duty breakout wrenches, holding forks, or irons.

Designed to withstand repeated loading and unloading, all DRILLMAX[®] drill pipe features a proprietary stress relief groove.

"The large groove cut into the back of pin threads increases fatigue life by removing the peak stress risers, which generally see high fluctuations in peak stresses and lead to fatigue cracking," Jed Davis, tooling design engineer, said.



Multiple sizes available in 20-foot length.

Part	MN	Weight
2.38 OD x 240 S-S (2.0 IF)	238918	128 lbs.
3.00 OD x 240 S-S (2-3/8 MR)	237404	142 lbs.
3.50 OD x 240 S-S (2-3/8 IF)	238005	198 lbs.
4.50 OD x 240 S-S (3-1/2 IF) <small>interchangeable with API NC38 or 4-1/2 SH</small>	238006	340 lbs.
4.50 OD x 240 S-S (2-7/8 IF) <small>interchangeable with API NC31 or 3-1/2 SH</small>	240711	340 lbs.

**Mayhew Regular —
More than 15% Lighter.
More than 15% Stronger.
More than 30% More Flow Capacity.**

S-S (Shoulder to Shoulder)

Hoist Plugs	MN	Notes
Spring Assisted Swivel Hoist Plug	239976	2-3/8 MR
Spring Assisted Swivel Hoist Plug	239983	2-3/8 IF
Spring Assisted Swivel Hoist Plug NEW	240638	2-3/8 MJ
Spring Assisted Swivel Hoist Plug NEW <small>build to order</small>	240665	AWJ
Spring Assisted Swivel Hoist Plug NEW <small>build to order for legacy machines</small>	242945	2-3/8 MJ
Backloading Hoist Plug NEW	240181	2-3/8 MJ
Backloading Hoist Plug NEW	240207	2-3/8 MR
Backloading Hoist Plug NEW	240209	2-3/8 IF
Backloading Hoist Plug NEW <small>DM650 mud</small>	241555	3-1/2 IF
Backloading Hoist Plug NEW <small>DM650 air</small>	241559	2-7/8 IF

DRILLMAX[®] Adapter Subs

DRILLMAX[®] manufactured adapter subs ensure consistent, high-quality parts with the convenience of one-stop shopping.

- lengths suited to machine and application
- available on the shelf



2 3/8 Mayhew Regular, 2 3/8 IF, 3 1/2 IF, 2 7/8 IF, Bit Subs Available



SCAN TO WATCH
Spring Assisted Hoist Plugs





Back to Our Roots

Four decades ago Michael Barlow began installing pumps and drilling wells with one rig. He diversified into commercial geothermal projects in the early '90s. Today **MICHAEL BARLOW DRILLING & SERVICE INC.** completes as much service volume as drilling. This includes water treatment services for whole house and point of use as well as pump service and repair.

"In 2000-01, we completed what was then the largest geothermal project in North Carolina drilling 656 boreholes, 500-foot deep to serve as the main heating and cooling for the entire 100-acre campus," Barlow, president, said. "The commercial market became more competitive and with the market saturated, margins weren't there anymore. We diversified, adding services, and got back to our roots."

With the high price of new equipment, Barlow sought a way to get into a newer drill without years of financing.

"We felt like for half the money we could basically have a new machine, which was a better return on our investment," Barlow said. "We could use it to make some money and double the resale value if we decided to sell it, bringing us halfway to buying a new rig."

Familiar with the Geoprobe®/DRILLMAX® East Coast Service Center's knowledgeable mechanics and having seen previous quality refurbishments, Barlow employed their services for his refurbishment.

"The refurbished rig has lived up to every expectation we had, and they stand behind it. They came out and helped us with start up. They're good mechanics who know what they're doing," Barlow said. "We had the refurb done nearly two years ago and it's performed like a new one. They did a great job."



He's been so impressed, he's preparing to have a second refurbishment completed at the Geoprobe®/DRILLMAX® East Coast Service Center.

"Equipment is not designed to continually take abuse, especially in geothermal where it's all about production," Barlow said. "It's like your body. If you're working 12-hour days, not sleeping, not taking care of it — your body and everything around you suffers."

His desire to take a basic drill machine, get it as new as he could, and get the best return on investment he could has been met — and more.

"We used a company we can count on and who really cares about the industry," Barlow said. "Geoprobe®/DRILLMAX® is now backing us. They're good people willing to help us and ensure we have what we need."

**CALL FOR
AVAILABLE
PARTS**

Service

- Geoprobe®
- DRILLMAX®
- Schramm
- REICHdrill
- Ingersoll Rand
- Boart Longyear
- Sandvik

Parts

- Geoprobe®
- DRILLMAX®
- Schramm
- REICHdrill
- Ingersoll Rand
- Boart Longyear
- Sandvik
- Sullair
- Eaton
- Timken
- Lovejoy
- American Mfg Company



610-467-1750

Attention Schramm Rig Owners

We recognize the ever-changing challenges customers face in our industry. Please know we are here to help with parts and service so you continue to succeed in the field.

Our East Coast Service Center team has extensive expertise sourcing parts and servicing Schramm drill rigs. With their history within the Schramm organization, they can offer you:

- **60-YEARS COMBINED SCHRAMM EXPERIENCE:** *engineering, service, assembly, operations*
- **SPECIALTY TOOLS**
- **PARTS INVENTORY & SOURCING CONNECTIONS**

Give us a call and we'll work to find you a solution: 610-467-1750.



**Geoprobe[®]/DRILLMAX[®]
EAST COAST SERVICE CENTER**
Oxford, Pennsylvania

610-467-1750



SEVENTEENTH SERVICE CENTER follows through on promises for repairs on parts for any make or model rig like this top head drive.



Having owned **J&J WATER WELL & WINDMILL SERVICES** since 2013, Robbie Barnard implemented drilling services in 2020.

"Business just exploded once word got out that we were full service," Barnard said. "It's been a game changer doing 100 percent of anything dealing with water wells."

Full-service for the self-proclaimed 'mom-and-pop' shop in Texas includes restoring, replacing, and repairing windmills, inviting them into ranch work.

"I am intrigued by the challenge of solving problems. I like the brain tease of figuring out stuff that most people don't want to mess with — that's how we got into windmills," Barnard said. "We have key and gate codes to a half-million acres of ranches around us."

When he sought out a local shop to solve a top head drive problem, the shop didn't disclose they had never completed that type of work before.

"When I called back three weeks later, they hadn't even touched it," Barnard said.

Having called Todd Ewing at the Geoprobe[®]/DRILLMAX[®] Southeast Service Center in Ocala, Florida, over the years for parts, he reached out to him regarding the top head drive issue and was advised he could be taken care of the same day.

"I dropped it off at 7 a.m. Tuesday and was back on the road by 1 p.m.," Barnard said. **"I've never had customer service like that. You really can't ask for more."**

For Barnard, the Geoprobe[®]/DRILLMAX[®] Southeast Service Center's ability to follow through on their word is worth a 16-hour drive to Ocala, Florida.

"They do what they say they'll do, which means the world to me," Barnard said. "I've already arranged transfer case repairs. I'll call a couple weeks before I'm ready to bring them so they can have the parts on stand by, and they said they'll get me taken care of with just a night's stay."

Quality service and clean condition of the shop provides peace of mind.

"Todd is quick with his part numbers — kudos to him. He's been a big help on parts to me over the years," Barnard said. **"I was impressed by how clean and organized the shop was. You wouldn't think it was a drill repair shop. I'm 100 percent satisfied."**

SOUTHEAST SERVICE CENTER

Service Worth a 16-hour Road Trip



SCAN TO WATCH
Who Is Geoprobe®?

Rigs, Tools, and Techniques for Fieldwork Simplified

- Water Well
- Geothermal
- Cathodic Protection
- Geotechnical
- Environmental
- Mineral Exploration
- Construction
- Dewatering
- Mining
- High Resolution Site Characterization
- Cone Penetration Testing



Going the Distance with Geoprobe®/DRILLMAX®

Getting their start in 1992 doing mostly environmental work at gas stations, **SHEPLER WELL DRILLING** does 75 percent environmental and 25 percent residential work. Lately a lot of their work involves production wells and recovery wells in oil fields. Running predominantly Geoprobe® rigs and larger rotary rigs, Randy Shepler, president of the Michigan company, sought a solution to their mobilization woes.

"I bought the DRILLMAX® DM250 for environmental and residential because we travel so much," Shepler said. "Another manufacturer stopped by and had us look at one of theirs, but I decided to go with what I know. Geoprobe® offers superior service and that means a lot."

His history and experience with Geoprobe® tipped the scales to DRILLMAX®.

"I knew we would have service after the sale and would be able to get questions answered. They're available when you call, and you're not spending time playing phone tag," Shepler said. **"I've had a few questions and needed to order some tooling. We had a hydraulic leak when I first got the rig, and they came right out and fixed it. That's why you buy from Geoprobe®/DRILLMAX® — they're really helpful."**

They primarily use the DM250 to install 5-inch PVC residential wells and some deep environmental 2-inch wells. He's been surprised by the amount of torque on the DM250.

"They say it has a lot, but it's more than I anticipated. We use a 14-inch auger to set the conductor, and at this time of the year, it's all frost, but I have the torque to complete the work," Shepler said. "We've done 80-foot to 160-foot wells, used air rotary recently on a landfill, and augered 14-inch hole through cobble and clay to set a conductor on top of bedrock. I was prepared to have to mud rotary drill in the conductor, but the rig had no problem turning the 14-inch auger."

For Shepler, the rod handler and ease of operation provides an advantage for training the next generation of driller.

"The DM250 is small so it isn't intimidating and is easy to run, but it can still do everything we need a big rig to do," Shepler said. **"I've got my new guy running it, and it was easy to train him on."**

Pleased with the purchase, Shepler says it has met their expectations and then some — including easing their travel troubles.

"It's nice to hop in a small rig to drive long distances," Shepler said.

Geoprobe® Innovation Differentiates Drill Rigs

Initially redefining environmental site investigations, Geoprobe® continually advances the drilling industry worldwide by designing and manufacturing rigs and tooling to make drilling jobs faster, easier, and safer.

Adding the DRILLMAX® line of rotary drill rigs in 2017, Geoprobe® began bolstering the DRILLMAX® 40-year reputation in the water well and geothermal industry by enhancing manufacturing processes to ensure durability and easy maintenance.

Innovation Never Stops

Customer input inspires ongoing investment in innovation to continually refine a range of Geoprobe® and DRILLMAX® drill rigs. Constant contact with drillers in the field gleans knowledge on challenges faced and proposed solutions. This atmosphere of innovation and driller feedback fuels our work to make the rigs built in 2023 and 2024 better than they were not many weeks or months ago.

View complete line of rigs:



geoprobe.com/DRILLING-RIGS

Team Geoprobe® Growing

We're growing and ready to invest in passionate, skilled individuals based in Canada and Western United States to represent our products. If you check 'yes' to the questions below, **complete an application at: geoprobe.com/RepJob**

I WOULD LIKE TO USE MY DRILLING BACKGROUND TO...

- ✓ run rigs in the field, teaching new techniques.
- ✓ connect drillers to solutions, talking daily.
- ✓ provide top customer service, contributing ideas for innovation.
- ✓ engage industry leaders, traveling to help customers.

Factory Visit Reveals Manufacturing Expertise

Whether a veteran driller or just starting out, a factory visit provides valuable insight when making the investment required to purchase a new rig. Taking time to see firsthand how the rig you're considering is engineered and manufactured and meeting the service technicians you'll be partnering with throughout the rig's operation can solidify decisions when preparing to part with that much cash.

Veteran Driller

In the drilling industry since 1975, Jim Mack Sr drilled in Saudi Arabia; Houston; Egypt; and Illinois before he saw an ad for an existing Oregon drilling business. In 1988 he bought **BANDON WELL & PUMP COMPANY** along with its two cable tool rigs and became a one-man show. After six-months, his wife left her job to run the office, serving as the "entrepreneur and planner," while Mack was the "worker bee."

"She asked me where I wanted to be in five years, and I told her I wanted a rotary rig. So in five years we bought our first rotary rig. She made the business where everything would flow," Mack said. "She died in 2020, and I still miss her. I'm now approaching my end of life in this business, and my son joined the business after he graduated college. When I move on, I want him to have reliable equipment to keep his head afloat."

What began as a one-man operation, now employees seven individuals and has done more than \$1 million per year the past several years. One of their rigs now has obsolete parts requiring going to a machinist or making them himself, the truck is falling apart, and "it's just become a pain to work on."

"They don't last forever. It would be nice to have a new piece of equipment to go to the field to work, not to work on," Mack said. "It's an investment, but we figure our production rate will go up with less downtime and a faster rig."

Firm in his decision to invest in new equipment, Mack then sought to find the right rig. That's when Donnie Wood suggested he fly out and check out the Geoprobe®/DRILLMAX® factory. While in Salina, Kansas, he got to see a rig operate and much more.

"I was impressed by the whole manufacturing process. I went on a tour, and they showed me different stages where things are put together. They make everything but the truck," Mack said. "Everyone working there looked happy to be there. A lot of employees have a farming background with a strong work ethic."



OR

Watching DRILLMAX® rigs run on a factory visit concludes with opportunity to chat with team members engineering and building the rigs.

He was also impressed by the availability of parts and ability to view service records in Centerpoint Connected.

"They showed me where they keep parts on the shelf. You're not waiting for something to happen when you order something; it is sitting there and shipped out the next day," Mack said. "They track the machines by serial number in Centerpoint Connected and you can see the service notes and different parts ordered."

While at the factory, he was able to discuss and review with engineering specific rig performance and options important to him.

"I've been to other manufacturing plants — for pumps etc. — but never a drill rig factory. Going to the plant and seeing it all and the smooth operation of it all — I was blown away," Mack said. "I believe coming to the factory was a game changer."

Beginning Business

Currently working as an apprentice driller toward their own Texas license, **J4 WATER WORKS LLC** began business to fill a void in their area of Texas for drilling smaller 4- to 5-inch water wells, 100- to 200-foot deep.

"We chose the DM250 because we were seeking an efficient machine to put in more wells than the competition with less labor," Cuatro Strack, owner, said. "It was hard to look at any other options because we knew they would take more time than the DM250 to run and service."

He appreciates the constant innovation taking place on the product line while keeping operation simple with few electronics he described as being hard to troubleshoot.

"A simple, mechanical rig is the ticket to making money day-in and day-out in the field," Strack said.

He credits Donnie Wood for being responsive before and after the sale.

"His level of commitment never changes. We spent nine months in conversation before I bought the rig, and he's been just as responsive after the sale," Strack said.

After finalizing his purchase of the DM250, Strack landed in Salina, Kansas, for a pheasant hunt and decided if he was that close he had to make a visit. He was impressed by how clean the shops were and how everyone was on task to do what needed to be done, including the service technicians.

"The service guys really know what's going on, what's on the machine, and have parts on hand," Strack said. "Service after the sale is a big plus for buying a rig. Others can sell you a rig, but they better be able to sell it cheaper because their service isn't as good."

For Strack, the manufacturing capabilities shocked him.

"I was most surprised by how much manufacturing is completed versus just assembling parts," Strack said. "The big CNC machines producing top head parts and things — the level of manufacturing expertise is high."



SCAN TO WATCH
Value of Centerpoint Connected



- find facts quickly:
 - machine records
 - service notes
 - tooling/service orders
- store own machine notes

Sign up for FREE tool:  drillmaxrigs.com/CP



“When DRILLMAX® joined with Geoprobe® in 2017, we added the advantage of all these small groups working together in Kansas who want to put the best product possible in the field. That doesn't just mean the best machine. It means the best service. The best assembly. The best paint. The best of everything.

There's a large group of engineers who put a lot of thought into the designs. They always put the first new rig together themselves, figuring out how they can make it better; how they can help make your job easier; and thinking about what it is going to be like to change a part in the field or someone's shop.

I know it's a busy time, but I encourage you to make the trip to the factory. You'll be happy you did.

— Donnie Wood, DRILLMAX® Sales Representative



Geoprobe®/DRILLMAX® team of machine design engineers

PRSR STD
U.S. Postage
PAID
Permit NO. 476
Wichita, KS



1835 Wall St
Salina, KS 67401

Change Service Requested

REQUEST A FACTORY TOUR  785-825-1842

DRILLMAX®

Geoprobe PRODUCTS SPECIFICALLY DESIGNED FOR WATER WELL AND GEOTHERMAL CONTRACTORS

TOOLS-IN-THE-GROUND EVENT

Come see DRILLMAX® DM250 on F600 in action.

- March 24, 2023 — Lansing, Michigan

2024 OPEN HOUSE

Come visit with engineers and other industry leaders for this tools-in-the-ground event. See NEW rig and tooling offerings revealed to the public for the first time.

- APRIL 2024 — Salina, Kansas

STAY UP-TO-DATE

Follow us on social media!

 @drillmaxrigs
@geoprobesystems



SCAN TO WATCH

Product and Maintenance Videos Continually Added to the Website

For more information on what you read in this issue, contact us at:

DRILLMAXRIGS.COM • 785-825-1842

DRILLMAX®, Geoprobe®, Geoprobe Systems®, Macro-Core®, and Direct Image® are registered trademarks of Kejr Inc.

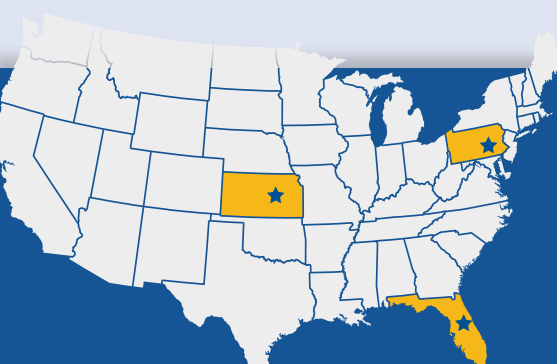

NOW with 3 Service Centers

offering expertise, tools, and parts inventory for rig repairs to refurbishments.

EAST COAST SERVICE CENTER
Oxford, Pennsylvania
610-467-1750

SOUTHEAST SERVICE CENTER
Ocala, Florida
352-854-1566

FACTORY SERVICE CENTER
Salina, Kansas
785-825-1842