

GEOPROBE® SCREEN POINT 22 GROUNDWATER SAMPLER

STANDARD OPERATING PROCEDURE

Technical Bulletin No. MK3173

PREPARED: April 2010

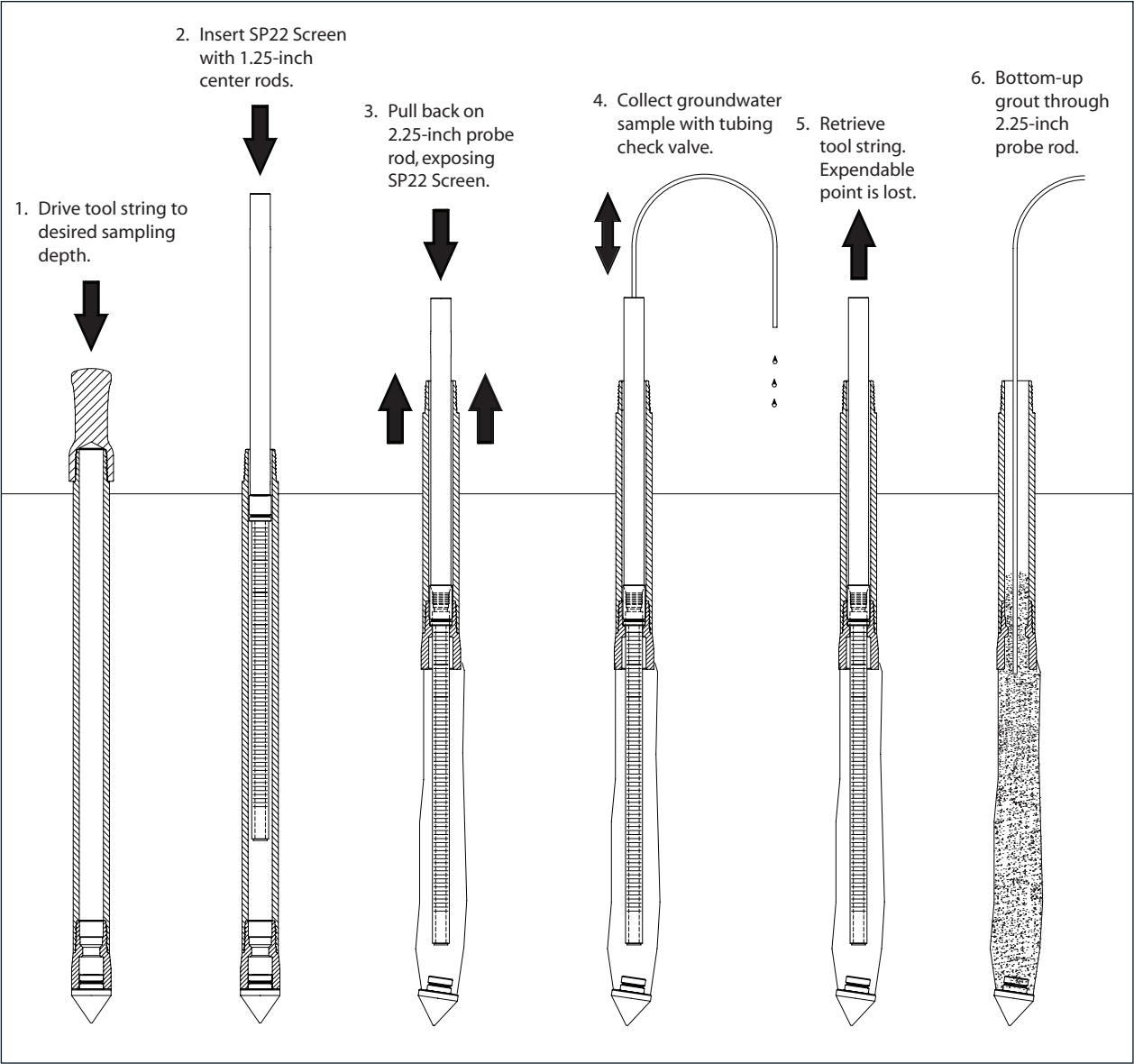

OPERATION OF THE GEOPROBE® SCREEN POINT 22 GROUNDWATER SAMPLER



**Geoprobe® and Geoprobe Systems®, Macro-Core® and Direct Image® are
Registered Trademarks of Kejr, Inc., Salina, Kansas**

**Screen Point 22 Groundwater Sampler is manufactured
under U.S. Patent 5,612,498**

**COPYRIGHT© 2010 by Kejr, Inc.
ALL RIGHTS RESERVED.**

No part of this publication may be reproduced or transmitted in any form
or by any means, electronic or mechanical, including photocopy, recording,
or any information storage and retrieval system, without permission in
writing from Kejr, Inc.

1.0 OBJECTIVE

The objective of this procedure is to deploy a stainless steel or PVC screen at depth, obtain a representative water sample from the screen interval, and grout the probe hole during abandonment. The Screen Point 22 Groundwater Sampler enables the operator to conduct abandonment grouting that meets American Society for Testing and Materials (ASTM) Method D 5299 requirements for decommissioning wells and borings for environmental activities (ASTM 1993).

2.0 BACKGROUND

2.1 Definitions

Geoprobe®: A brand name of high quality, hydraulically powered machines that utilize static force and percussion or rotation to advance sampling and logging tools into the subsurface. The Geoprobe® brand name refers to both machines and tools manufactured by Geoprobe Systems®, Salina, Kansas. Geoprobe® tools are used to perform activities such as soil core and soil gas sampling, groundwater sampling and monitoring, soil conductivity and contaminant logging, grouting, and materials injection.

Screen Point 22 (SP22) Groundwater Sampler: A direct push device consisting of a PVC or stainless steel screen that is lowered (post-run) to depth within a sealed string of steel probe rods and then deployed for the collection of representative groundwater samples. Upon deployment, up to 48 inches (1219 mm) of screen can be exposed to the formation. There is also an optional 12-inch screen that can be used. The Screen Point 22 Groundwater Sampler is designed for use with 2.25-inch probe rods and machines equipped with the more powerful GH60 and GH80 series hydraulic hammers. Operators with GH40 series hammers may choose to use this sampler in soils where driving is easier.

Rod Grip Pull System: An attachment mounted on the hydraulic hammer of a direct push machine which makes it possible to retract the tool string with probe rods or flexible tubing protruding from the top of the probe rods. The Rod Grip Pull System includes a pull block with rod grip jaws that are bolted directly to the machine. A removable handle assembly straddles the tool string while hooking onto the pull block to effectively grip the probe rods as the hammer is raised. A separate handle assembly is required for each probe rod diameter.

2.2 Discussion (Fig. 2.1)

In this procedure, 2.25-inch probe rods are advanced into the subsurface with a Geoprobe® subsurface machine (Fig. 2.1, Step 1). While the tool string is advanced to depth, O-ring seals at each rod joint, the expendable point holder, and the expendable drive point provide a watertight system. This eliminates the threat of formation fluids entering the screen before deployment and assures sample integrity.

Once the leading end of the 2.25-inch probe rods reaches the desired sampling interval, an SP22 screen is lowered to the bottom of the rods using a string of either 1.25-inch outside diameter (OD) light-weight center rods, 1.25-inch probe rods, or 0.75-inch schedule 40 flush-thread PVC riser (Fig. 2.1, Step 2). The 2.25-inch rods are then retracted while the SP22 screen is held in place with the 1.25-inch rods or PVC riser (Fig 2.1, Step 3). As the 2.25-inch tool string is retracted, the expendable point is released from the expendable point holder. The tool string and expendable point holder may be retracted the full length of the screen or as little as a few inches if a small sampling interval is desired.

The SP22 Sampler can also be used with the Geoprobe® DT22 system. (Fig. 2.2)

(continued on following page)

Expendable Drive Points

The SP22 system utilizes an SP22 Expendable Point Holder (33764) and standard 2.45-inch (62-mm) OD steel Expendable Drive Points for 2.25-inch probe rods (AT2015K). Extended Shank Expendable Drive Points (19442) are available for soft soil conditions where standard points may be advanced out of the point holder during percussion. A third option is to use a part number 43128 SP22 Expendable Point Holder along with 1.625-inch (41-mm) steel Expendable Drive Points (GW1555K). These smaller drive points are more economical to purchase and ship, but must not be used with GH80 Series Hydraulic Hammers as they may not stay seated during percussion.

Screens

Two types of screens have been developed for use in the Screen Point 22 Groundwater Sampler - a stainless steel screen with a standard slot size of 0.004 inches (0.10 mm) and a PVC screen with a standard slot size of 0.010 inches (0.25 mm). These screens are available in nominal 48- and 12-inch lengths. Effective screen lengths for the 48- and 12-inch PVC screens are 48 inches (1219 mm) and 12 inches (305 mm), while 48- and 12-inch stainless steel screens have effective screen lengths of 43 inches (1092 mm) and 14 inches (356 mm) respectively. Both types of screens are recovered with the tool string after sampling.

The SP22 PVC Screen Head Adapter (37871) provides yet another screen option for the SP22 sampler. Using this adapter, a section of slotted 0.75-inch Schedule 40 PVC pipe may be lowered through the 2.25-inch probe rods using a string of flush-threaded 0.75-inch Schedule 40 PVC Riser. An SP22 PVC Screen Plug (38968) is installed in the leading end of the slotted pipe prior to use. The slotted pipe may be cut and the screen plug installed to provide custom screen lengths.

An O-ring is located at the top of each stainless screen and on the screen adapters. When a screen is deployed, this O-ring maintains a seal between the top of the screen and the inner wall of the probe rods or expendable point holder as indicated in Figure 2.1. As a result, any liquid entering the tool string must first pass through the screen.

Screens are constructed such that equipment can be inserted into the screen cavity for sample collection as noted in the following section and illustrated in Figure 2.1, Step 4. This makes direct sampling possible from anywhere within the saturated zone.

The inner rod string and screen are generally removed prior to grouting through the 2.25-inch rod string as shown in Figure 2.1, Steps 5-6. However, a removable plug in the lower end of the screens allows for grouting through flexible tubing extending out the bottom of the screen as with the Geoprobe® SP15/16 Groundwater Samplers if desired.

Sample Collection

Groundwater samples can be obtained from the SP22 screen in a number of ways. A common method utilizes 0.375-inch OD polyethylene (TB25L) or Teflon® (TB25T) tubing and a check valve assembly. The check valve (with check ball) is attached to one end of the tubing and inserted down the casing until it is immersed in groundwater. Water is then pumped through the tubing and to the ground surface by oscillating the tubing up and down.

An SP22 Check Valve Assembly (37893) is recommended if sampling through 1.25-inch light-weight center rods. The SP22 Check Valve Assembly is approximately 20 inches long to enable it to pass through the stepped diameters at each rod joint that may cause problems for other, shorter check valves.

An alternative means of collecting groundwater samples is to attach a peristaltic or vacuum pump to tubing that is inserted through the inner rods to within the SP22 screen. This method is limited in that water can be pumped to the surface from a maximum depth of approximately 26 feet (8 m). Another technique for groundwater sampling is to use a stainless steel Mini-Bailer Assembly (GW41). The mini-bailer is lowered down the inside of the casing below the water level where it fills with water and is then retrieved from the casing.

The latest option for collecting groundwater from the SP22 Sampler is to utilize a Geoprobe® MB470 Series Mechanical Bladder Pump (MBP)*. The MBP may be used to meet requirements of the low-flow sampling protocol (Puls and Barcelona 1996, ASTM 2003). Through participation in a U.S. EPA Environmental Technology Verification study, it was confirmed that the MB470 can provide representative samples (EPA 2003).

**The Mechanical Bladder Pump is manufactured under U.S. Patent No. 6,877,965 issued April 12, 2005.*

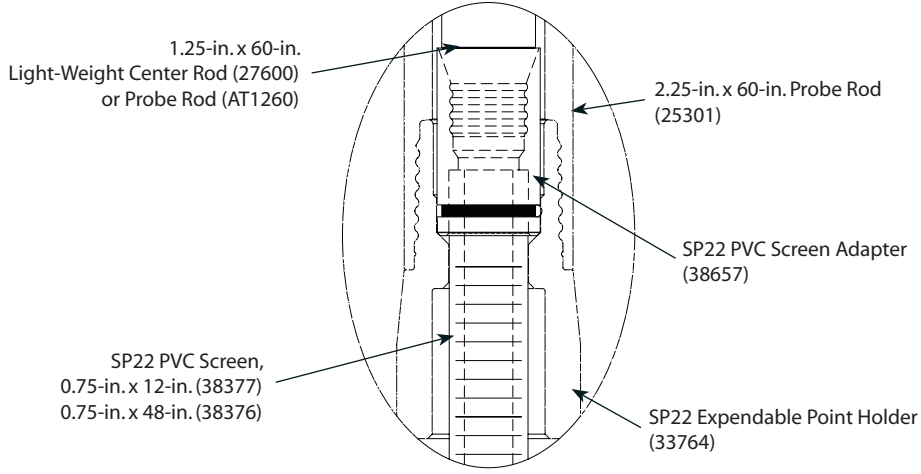
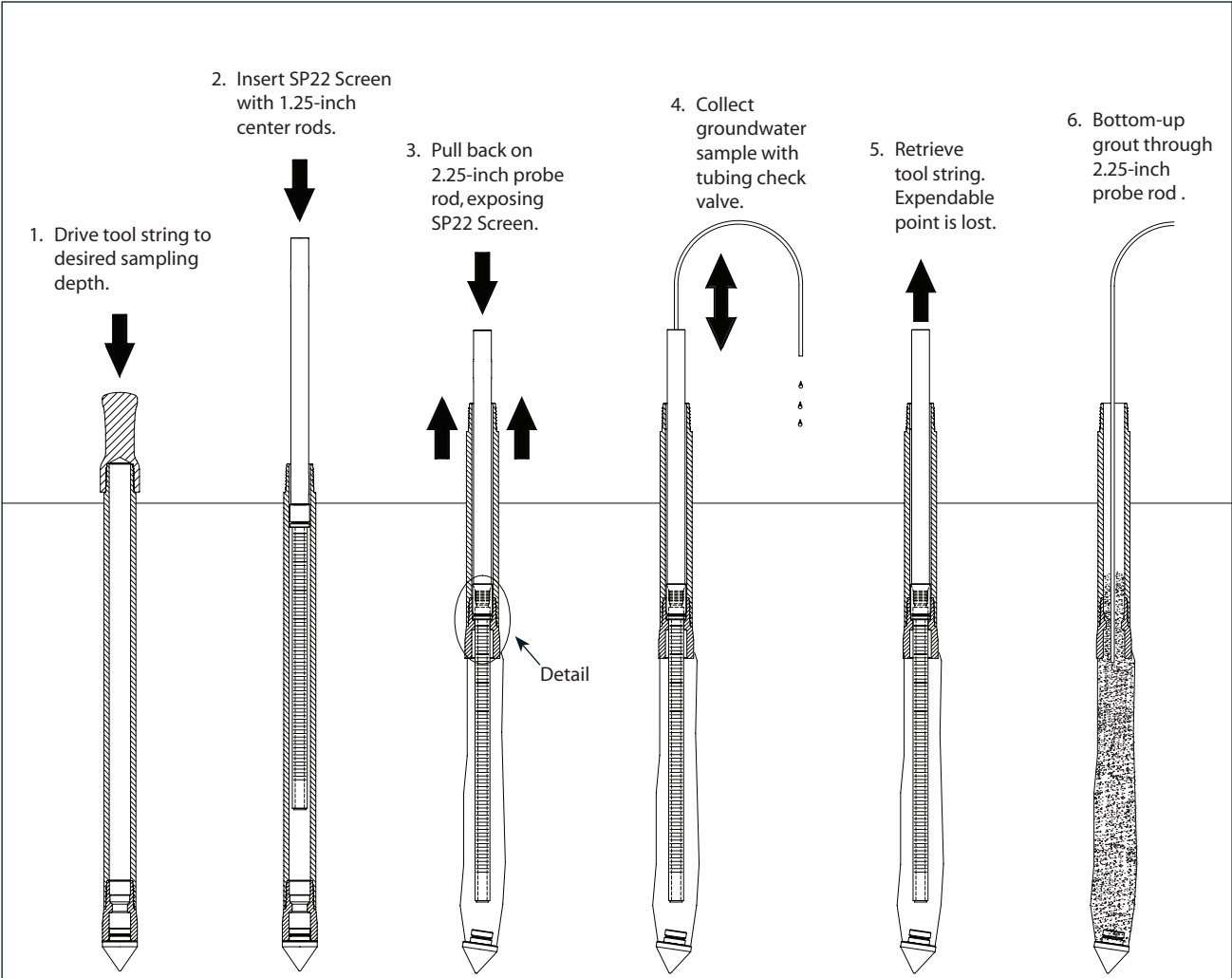

FIGURE 2.1
Screen Point 22 Groundwater Sampler - 0.75-inch PVC Screen Option

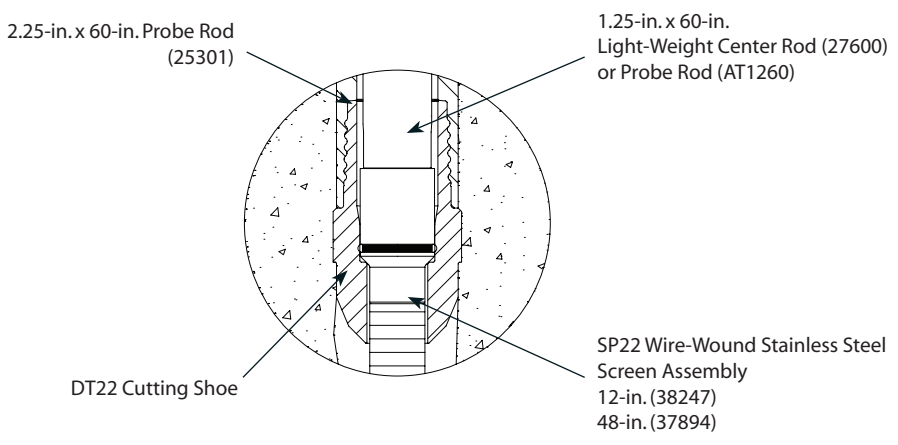
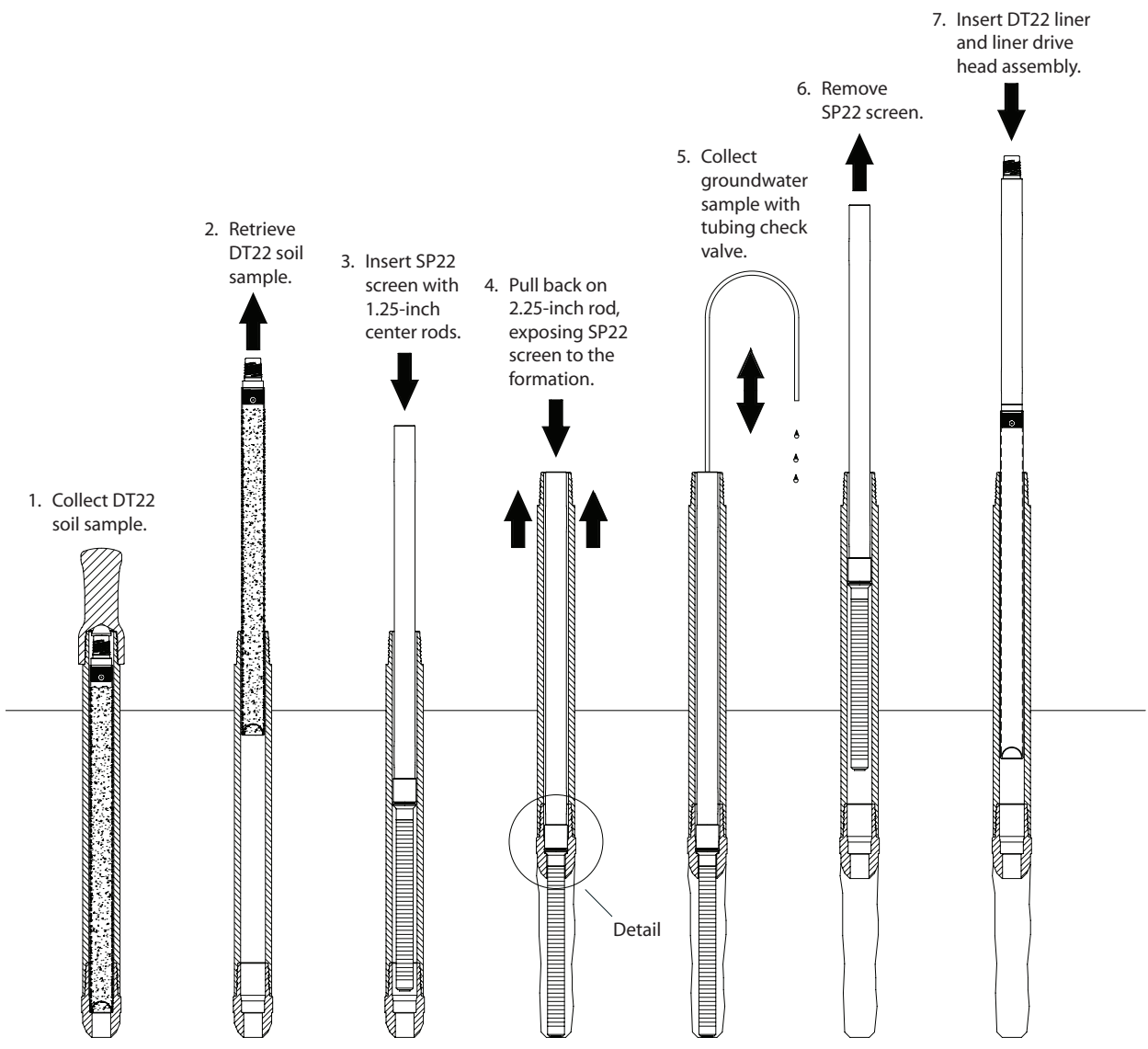

FIGURE 2.2
Screen Point 22 Groundwater Sampler Operation with DT22 Sampling System

3.0 TOOLS AND EQUIPMENT

The following tools and equipment can be used to successfully recover representative groundwater samples with the Geoprobe® Screen Point 22 Groundwater Sampler. Refer to Figures 3.1 and 3.2 for identification of the specified parts. Tools are listed below for the most common SP22 / 2.25-inch probe rod configurations. Additional rod sizes and accessories are available. Contact Geoprobe Systems® for information regarding tools and equipment options.

SP22 Sampler Parts	Part Number
SP22 Screen, Wire-Wound Stainless Steel, 4-Slot (48-in.)	37894
SP22 Screen, Wire-Wound Stainless Steel, 4-Slot (12-in.)	38247
Grout Plugs, PE (Pkg. of 25)	GW1552K
SP22 Screen, PVC, 10-Slot, 0.75-in. x 48-in.	38376
<i>SP22 Screen, PVC, 10-Slot, 0.75-in. x 48-inch, Kit (includes 2 each of 38376 and 38429)</i>	<i>38664</i>
SP22 Screen, PVC, 10-Slot, 0.75-in. x 12-in.	38377
<i>SP22 Screen, PVC, 10-Slot 0.75-in. x 12-in., Kit (includes 2 each of 38377 and 38429)</i>	<i>38667</i>
SP22 PVC Screen Plug	38968
<i>SP22 PVC Screen Plug Kit (includes 10 of 38968)</i>	<i>38530</i>
SP22 PVC Screen Adapter, 0.75-in. PVC x 1.25-in. Probe Rod Box	38657
SP22 PVC Screen Head Adapter, 0.75-in. (for flush-threaded 0.75-in. Schedule 40 PVC)	37871
SP22 O-ring Kit (Pkg. of 10 O-rings for SP22 PVC screen adapters and stainless steel screens) ...	37853
O-rings, 0.75-in. PVC Riser (Pkg. of 25)	GW4401R
SP22 Expendable Point Holder, 2.25-in. Probe Rods, AT2045K and 19442 Points	33764
SP22 Expendable Point Holder, 2.25-in. Probe Rods, GW1555 Points*	43128
Outer Casing (2.125-inch Probe Rods) and Inner Rod String	Part Number
Probe Rod, 2.25-in. x 60-in.	25301
Expendable Drive Points, Steel, 2.45-in. OD (Pkg. of 25)	AT2015K
Expendable Drive Points, Steel, 2.45-in. OD, extended shank	19442
Expendable Points, steel, 1.625-in. OD (Pkg. of 25)*	GW1555K
Drive Cap, 2.25-in. Probe Rods, Threadless, (for GH60 and GH80 Series Hammers)	31530
O-Rings, 2.25-in. Probe Rods (Pkg. of 25)	AT2100R
Rod Grip Handle, 2.25-in. Probe Rods, (for GH60 and GH80 Series Hammers)	29385
Light-Weight Center Rod, 1.25-in. x 60-in.	27600
Probe Rod, 1.25-in. x 60-in.	AT1260
O-ring, 1.25-in. rods (Pkg. of 25)	AT1250R
Rod Grip Handle, 1.25/1.5-in. Rods, (for GH60 and GH80 Series Hammers)	15554
PVC Riser, 0.75-in. Schedule 40 x 60-inch	11747
PVC Pipe, 0.75-in. Schedule 40 x 60-inch, 10-Slot	17474
Grout Accessories	Part Number
High-Pressure Nylon Tubing, 0.375-in. OD / 0.25-in. ID, 100-ft. (30 m)	11633
Grout Machine, Auxiliary-Powered	GS2200
Grout System Accessories Package, 2.25-in. rods	GS1015
Groundwater Purging and Sampling Accessories	Part Number
Polyethylene Tubing, 0.375-in. OD, 500 ft.	TB25L
Check Valve Assembly, 0.375-in. OD Tubing x 20 in. Long	37893
Water Level Meter, 0.438-in. OD Probe, 100 ft. cable	GW2000
Mechanical Bladder Pump**	MB470
Mini Bailer Assembly, Stainless Steel	GW41

* Not for use with GH80 Series Hydraulic Hammers

** Refer to the Standard Operating Procedure (SOP) for the Mechanical Bladder Pump (Technical Bulletin No. MK3013) for additional tooling needs.

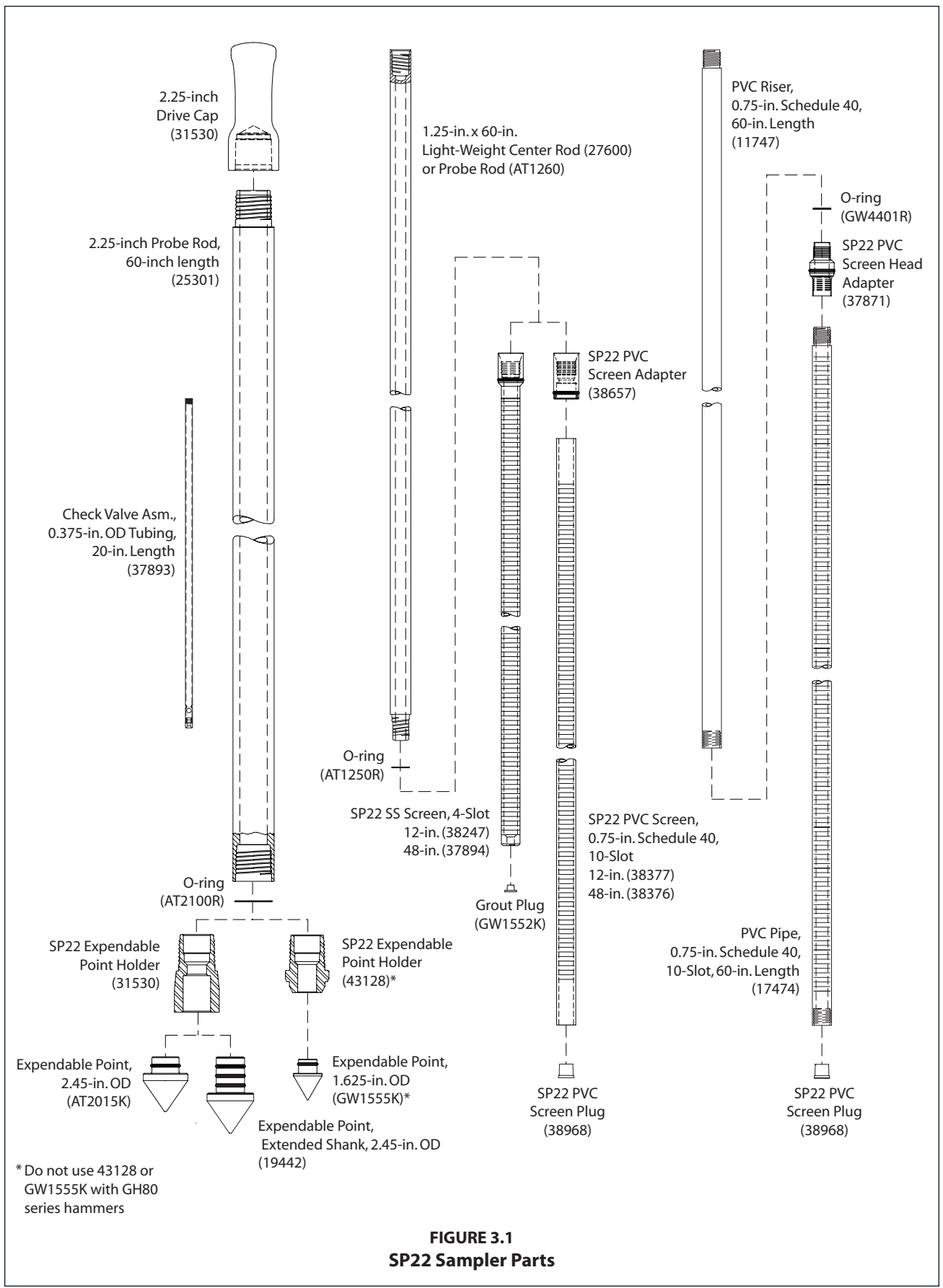

FIGURE 3.1
SP22 Sampler Parts

4.0 OPERATION

4.1 Basic Operation

The SP22 Sampler utilizes a stainless steel or PVC screen which is lowered (post-run) through an alloy steel 2.25-inch OD probe rod tool string. An expendable drive point is placed in an expendable point holder on the leading 2.25-inch probe rod prior to advancement (Fig. 4.1). This expendable point is removed and stays in the subsurface as the rods are pulled back to exposes the SP22 screen. O-rings on the probe rods, the expendable point holder, and the expendable drive point provide a watertight tool string which keeps contaminants out of the system as the 2.25-inch rods are driven to depth in preparation for installation of the SP22 screen.

Once the sampling interval is reached with the 2.25-inch probe rods, the stainless steel or PVC screen is lowered through the rods using 1.25-inch probe rods, 1.25-inch light-weight center rods, or 0.75-inch PVC riser pipe. The 2.25-inch tool string is then retracted while the screen is held in place with the inner rods or riser. The system is now ready for groundwater sampling. When sampling is complete, the inner rods and screen are removed for grouting during retrieval or the 2.25-inch rods. Alternatively, a removable plug is located in the bottom of the screens to allow grouting directly through the inner tool string with high-pressure tubing during retrieval.

4.2 Decontamination

In order to collect representative groundwater samples, all sampler parts must be thoroughly cleaned before and after each use. Scrub all metal parts using a stiff brush and a nonphosphate soap solution. Steam cleaning may be substituted for hand-washing if available. Rinse with distilled water and allow to air-dry before assembly.

4.3 Lead Rod Assembly (Fig. 4.1)

1. Place an O-ring on the expendable point holder.
2. Thread expendable point holder into the 2.25-inch probe rod.
3. Place an O-ring on a steel expendable drive point.
4. Firmly seat the expendable point in the expendable point holder.
5. Place 2.25-inch Drive Cap (31530) on the top of the 2.25-inch probe rod. The lead rod assembly is now ready to be driven to depth.

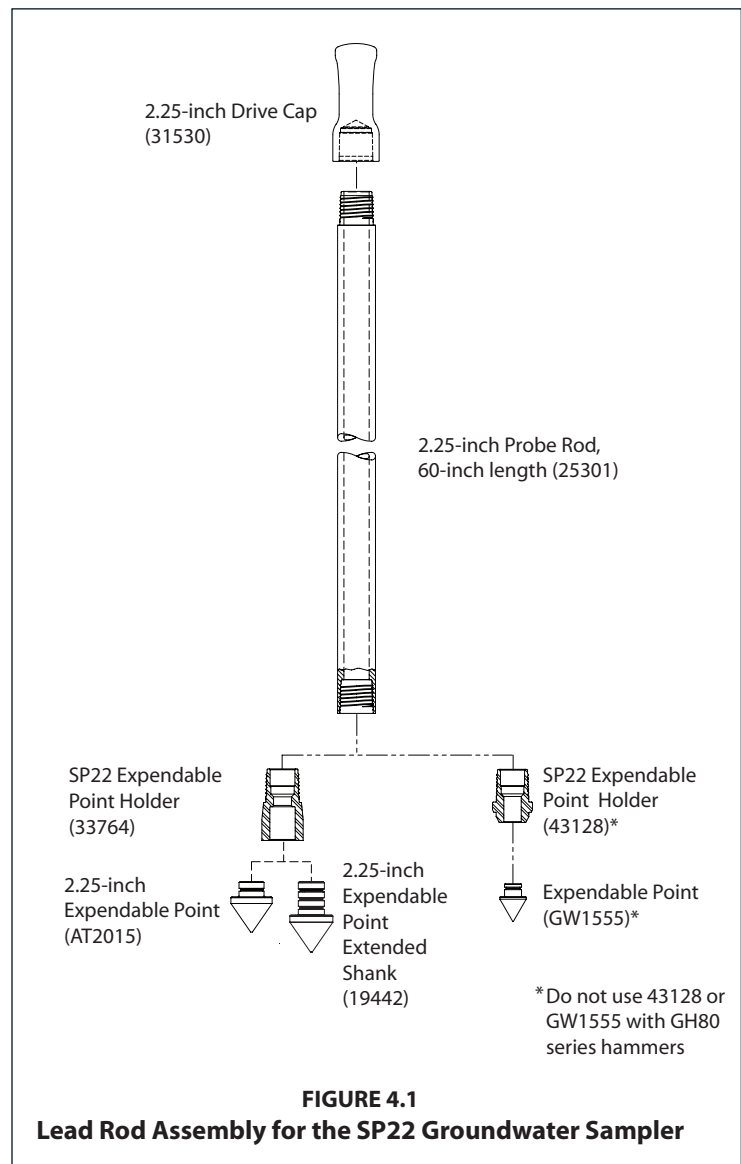

4.4 Advancing the Tool String (Fig. 4.2, step 1)

To provide adequate room for screen deployment with the Rod Grip Pull System, the probe derrick should be extended a little over halfway out of the carrier vehicle when positioning for operation.

1. Drive first 2.25-inch probe rod (as assembled in section 4.3).
2. Advance the tool string at a slow speed for the first few feet to ensure that the string is aligned properly.
3. Completely raise the hammer assembly. Remove the drive cap and place an O-ring in the top groove of the driven probe rod. Distilled water may be used to lubricate the O-ring if needed.

Add a probe rod (length to be determined by operator) and reattach the drive cap to the rod string. Drive the tool string the entire length of the new rod.

4. Repeat Step 3 until the desired sampling interval is reached. Approximately 12 inches (305 mm) of the last probe rod must extend above the ground surface to allow attachment of the puller assembly. A 12-inch (305 mm) rod may be added if the tool string is over-driven.
5. Remove the drive cap and retract the probe derrick away from the tool string.

4.5 Screen Deployment (Fig 4.2, step 2 - 4)

1. Attach an SP22 stainless steel or PVC screen to a 1.25-inch probe rod, 1.25-inch light-weight center rod, or 0.75-inch flush-thread PVC riser using an SP22 PVC Screen Adapter (38657) or SP22 PVC Screen Head Adapter (37871) as shown in Figure 3.1. Note that the 38657 screen adapter is connected to the SP22 PVC screen using the setscrews provided with the adapter.

and lower it into the driven casing.

2. Lower the screen into the 2.25-inch probe rod casing and add rods or riser until the screen head contacts the bottom of the tool string.
3. Ensure that at least 48 inches (1219 mm) of rods or riser protrudes from the top 2.25-inch probe rod.
4. Maneuver the probe assembly into position for pulling.
5. Raise (pull) the outer 2.25-inch tool string while physically holding the screen in place with the inner 1.25-inch rods or 0.75-inch riser. A slight knock with the inner tool string will help to dislodge the expendable point and start the screen moving inside the probe rod.

Raise the hammer and outer tool string to expose the desired length of screen. The inner rods will begin raising with the outer rods when the screen adapter contacts the necked portion of the expendable point holder or DT22 Cutting Shoe. Use care when deploying a PVC screen so as not to break the screen when it contacts the expendable point.

6. Remove the rod grip handle, lower the hammer assembly, and retract the probe derrick. Remove the top 2.25-inch probe rod.
7. Groundwater samples can now be collected with a mini-bailer, peristaltic or vacuum pump, tubing bottom check valve assembly, bladder pump, or other acceptable small diameter sampling device.

When inserting tubing or a bladder pump down the rod string, ensure that it enters the screen interval. The leading end of the tubing or bladder pump will sometimes catch at the screen head giving the illusion that the bottom of the screen has been reached. An up-and-down motion combined with rotation helps move the tubing or bladder pump past the lip and into the screen.

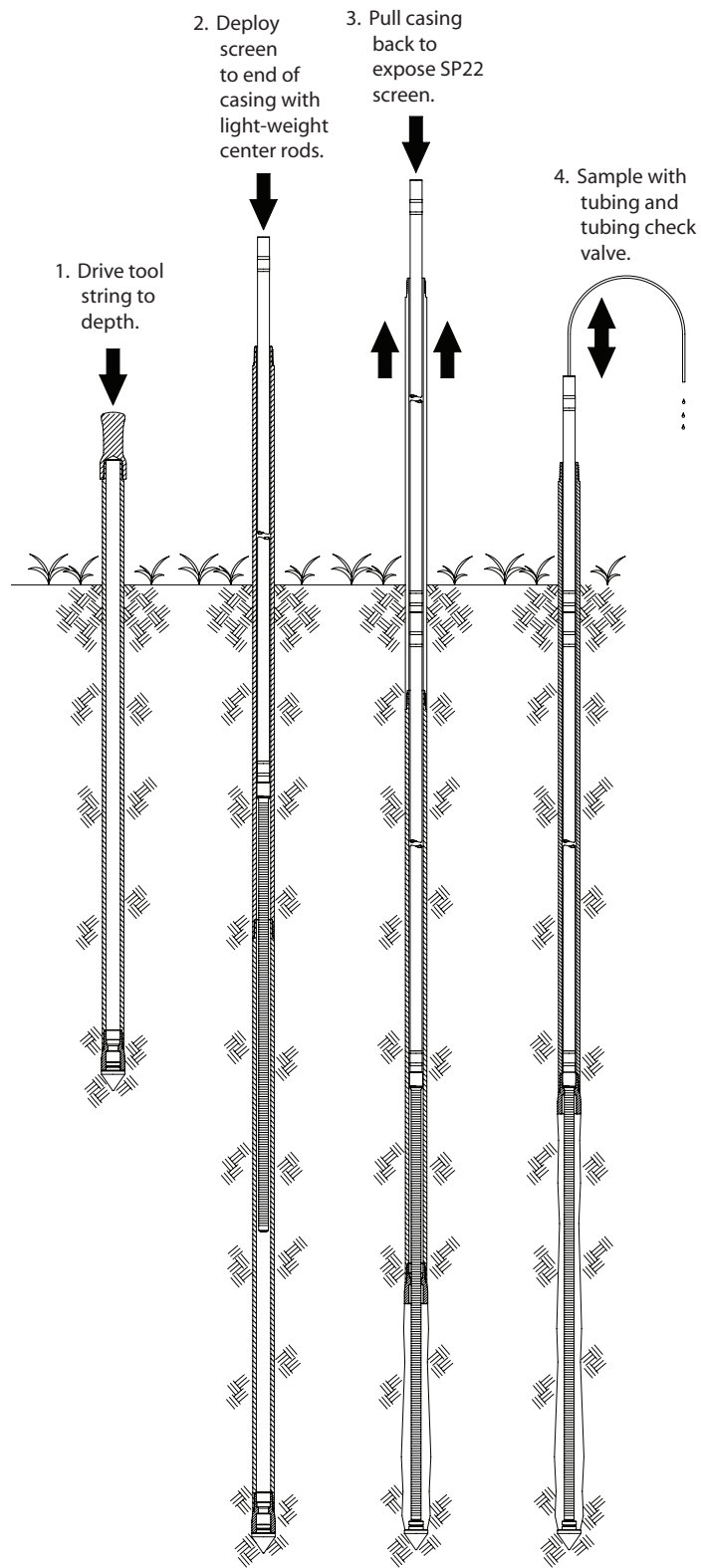

FIGURE 4.2
Screen Deployment for SP22 Sampler

4.6 Abandonment Grouting for SP22 Screens

The SP22 Sampler can meet ASTM D 5299 requirements for abandoning environmental wells or borings when grouting is conducted properly. A removable grout plug makes it possible to deploy tubing through the bottom of the SP22 screens, but the easiest method is to remove the inner string of rods; including the SP22 screen. A Grout Machine is then used to pump grout into the open probe hole as the outer casing is withdrawn. The following procedure is presented as an example only and should be modified to satisfy local abandonment grouting regulations. (Figure 4.3)

1. Maneuver the probe assembly into position for pulling.
2. High-Pressure Nylon Tubing (11633) is inserted down through the probe rods through the bottom of the expendable point holder (Fig. 4.3).

Note: All probe rods remain strung on the tubing as the tool string is pulled. Provide extra tubing length to allow sufficient room to lay the rods on the ground as they are removed. An additional 20 feet is generally enough.

3. Operate the grout pump while pulling the first rod with the rod grip pull system. Coordinate pumping and pulling rates so that grout fills the void left by the sampler. After pulling the first rod, release the rod grip handle, fully lower the hammer, and regrip the tool string. Unthread the top probe and slide it over the tubing placing it on the ground near the end of the tubing.
4. Repeat Step 5 until the tool string is retrieved. Do not bend or kink the tubing when pulling and laying out the probe rods. Sharp bends create weak spots in the tubing which may burst when pumping grout. Remember to operate the grout pump only when pulling the rod string. The probe hole is thus filled with grout from the bottom up as the rods are extracted.
5. Promptly clean all probe rods and sampler parts before the grout sets up and clogs the equipment.

4.7 Retrieving the Screen Point 22 Sampler

If grouting is not required, the Screen Point 22 Sampler can be retrieved by pulling the probe rods as with most other Geoprobe® applications. The Rod Grip Pull System should be used for this process as it allows the operator to remove rods without completely releasing the tool string. This avoids having the probe rods fall back downhole when released during the pulling procedure. A standard Pull Cap (33622) may still be used if preferred. Refer to the Owner's Manual for your Geoprobe® direct push machine for specific instructions on pulling the tool string.

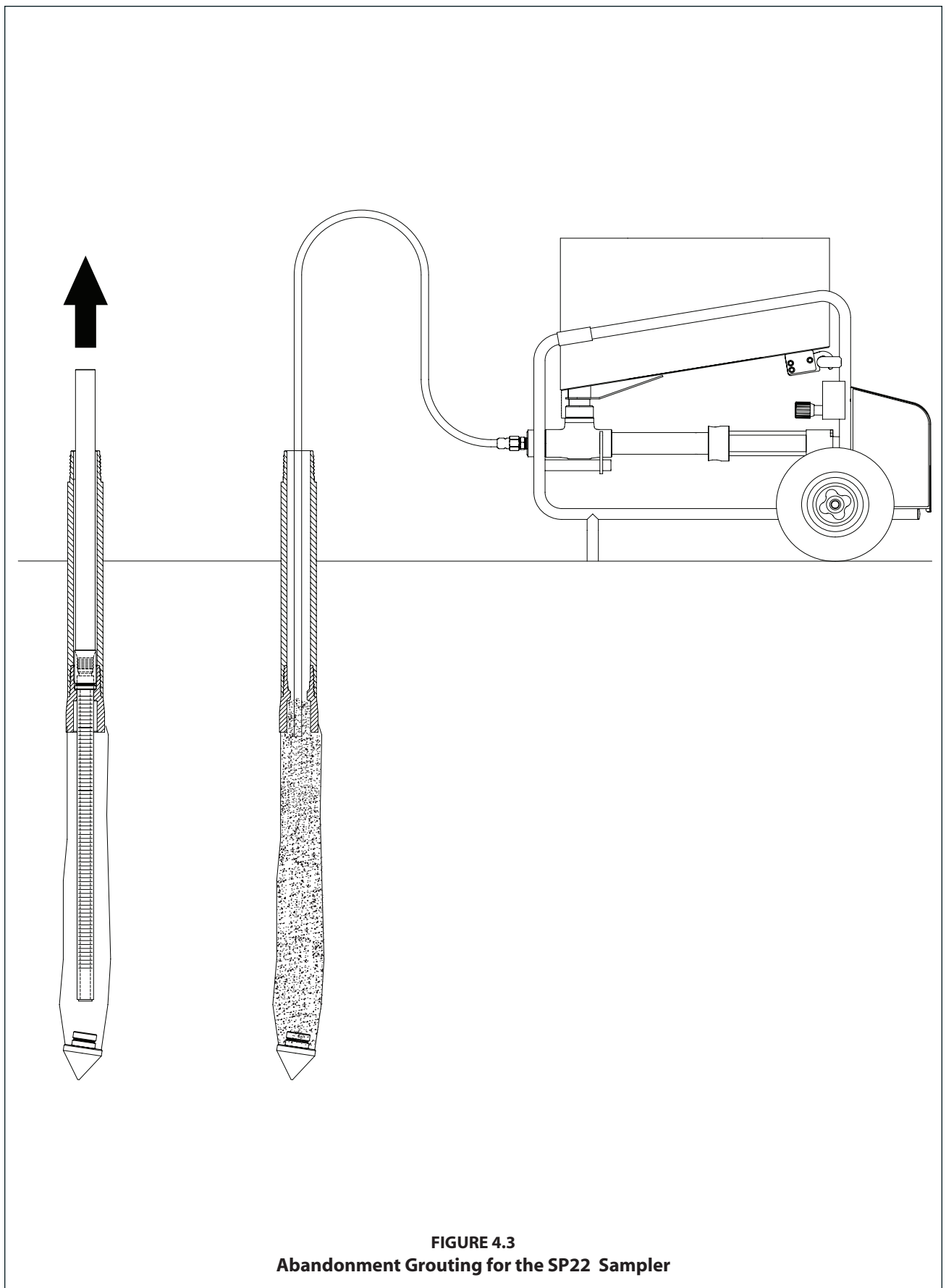

FIGURE 4.3
Abandonment Grouting for the SP22 Sampler

5.0 REFERENCES

- American Society of Testing and Materials (ASTM), 2003. D6771-02 Standard Practice for Low-Flow Purging and Sampling for Wells and Devices Used for Ground-Water Quality Investigations. ASTM, West Conshocken, PA. (www.astm.org)
- American Society of Testing and Materials (ASTM), 1993. ASTM 5299 *Standard Guide for Decommissioning of Groundwater Wells, Vadose Zone Monitoring Devices, Boreholes, and Other Devices for Environmental Activities*. ASTM West Conshohocken, PA. (www.astm.org)
- Geoprobe Systems®, 2003, *Tools Catalog, V.6*.
- Geoprobe Systems®, 2006, *Model MB470 Mechanical Bladder Pump Standard Operating Procedure (SOP), Technical Bulletin No. MK3013*.
- Puls, Robert W., and Michael J. Barcelona, 1996. Ground Water Issue: Low-Flow (Minimal Drawdown) Ground Water Sampling Procedures. EPA/540/S-95/504. April.
- U.S. Environmental Protection Agency (EPA), 2003. Environmental Technology Verification Report: Geoprobe Inc., Mechanical Bladder Pump Model MB470. Office of Research and Development, Washington, D.C. EPA/600R-03/086. August.

Equipment and tool specifications, including weights, dimensions, materials, and operating specifications included in this brochure are subject to change without notice. Where specifications are critical to your application, please consult Geoprobe Systems®.



A DIVISION OF KEJR, INC.

Corporate Headquarters

1835 Wall Street • Salina, Kansas 67401
1-800-GEOPROBE (1-800-436-7762) • Fax (785) 825-2097
www.geoprobe.com