

GEOPROBE MACRO-CORE[®] SOIL SAMPLER

STANDARD OPERATING PROCEDURE

Technical Bulletin No. 95-8500

PREPARED: November, 1995

REVISED: September, 1998

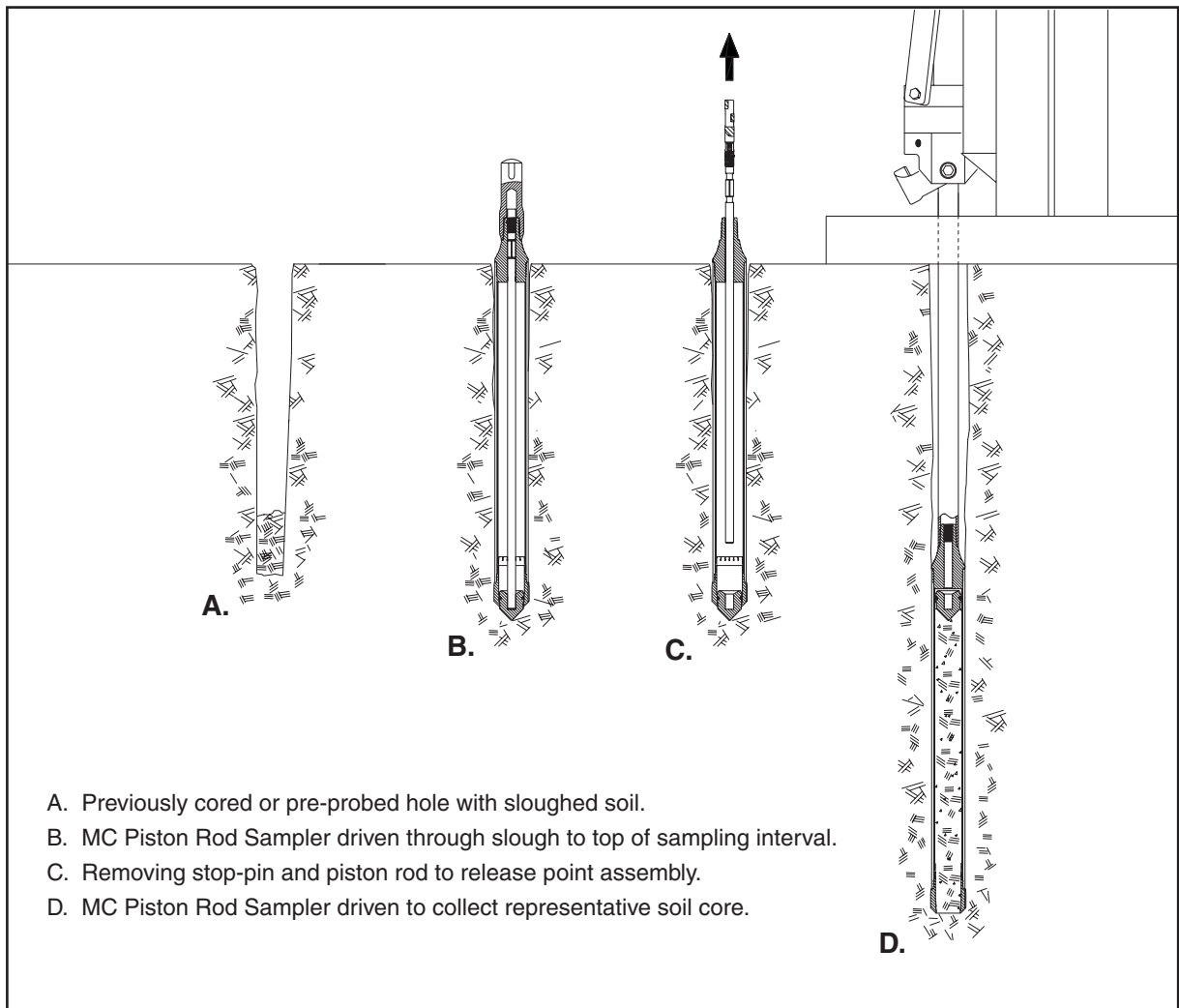

OPERATION OF MACRO-CORE[®] PISTON ROD SOIL SAMPLING SYSTEM



A DIVISION OF KEJR, INC.

**Geoprobe® is a Registered Trademark of
Kejr, Inc., Salina, Kansas**

**Macro-Core® is a Registered Trademark of
Kejr, Inc., Salina, Kansas**

**Macro-Core® Soil Sampler manufactured
under US Patent 5,606,139.**

**Macro-Core® Closed-Piston Drive Point
manufactured under US Patent 5,542,481**

COPYRIGHT© 1995, 1996, 1997, 1998 by Kejr, Inc.
ALL RIGHTS RESERVED.

No part of this publication may be reproduced or transmitted in any form or by any means, electronic or mechanical, including photocopy, recording, or any information storage and retrieval system, without permission in writing from Kejr, Inc.

1.0 OBJECTIVE

The objective of this procedure is to collect a representative soil sample at depth and recover it for visual inspection and/or chemical analysis.

2.0 BACKGROUND

2.1 Definitions

Geoprobe®*: A brand name of high quality, hydraulically-powered machines that utilize both static force and percussion to advance sampling and logging tools into the subsurface.

** Geoprobe® is a registered trademark of Kejr, Inc., Salina, Kansas*

Macro-Core® Soil Sampler*: A solid barrel, direct push device for collecting continuous core samples of unconsolidated materials at depth. Although other lengths are available, the standard Macro-Core® Sampler has an assembled length of approximately 52 inches (1321 mm) with an outside diameter (OD) of 2.2 inches (56 mm). Collected samples measure up to 1300 ml in volume in the form of a 1.5-inch x 45-inch (38 mm x 1143 mm) core contained inside a removable liner. The Macro-Core® Sampler may be used in an open-tube or closed-point configuration.

** Macro-Core® is a registered trademark of Kejr, Inc., Salina, Kansas*

Liner: A removable/replaceable, thin-walled tube inserted inside the Macro-Core® sample tube for the purpose of containing and storing soil samples. While other lengths are available, the standard Macro-Core® Liner is 1.75 inches OD x 46 inches long (44 mm x 1168 mm). Liner materials include stainless steel, Teflon®, PVC, and PETG.

2.2 Discussion

In this procedure, an assembled Macro-Core® Soil Sampler is driven one sampling interval into the subsurface and then retrieved using a Geoprobe soil probing machine. The collected soil core is removed from the sampler along with the used liner. After decon, the Macro-Core® sampler is reassembled using a new liner. The clean sampler is then advanced back down the same hole to collect the next soil core. The Macro-Core® Sampler may be used as an open-tube or closed-point sampler.

The Macro-Core® Soil Sampler is most commonly used as an open-tube sampler (Fig. 2.1A). In this configuration, coring starts at the ground surface with a sampler that is open at the leading end. The sampler is driven into the subsurface and then pulled from the ground to retrieve the first soil core. In stable soils, an open-tube sampler is advanced back down the same hole to collect the next core.

In unstable soils which tend to collapse into the core hole, the Macro-Core® Sampler can be equipped with a piston rod point assembly (Fig. 2.1B). The point fits firmly into the cutting shoe and is held in place by a piston rod and stop-pin. The MC Piston Rod System prevents collapsed soil from entering the sampler as it is advanced to the bottom of an existing hole, thus ensuring collection of a representative sample.

The Macro-Core® Piston Rod Sampler is not designed to be driven through undisturbed soil. A probe hole must be opened above the sampling interval either by removing continuous soil cores with an open-tube sampler, or by advancing a Macro-Core® Pre-Probe to depth.

Once a hole is opened to the appropriate depth, an assembled MC Piston Rod Sampler is advanced through any slough material to the top of the next sampling interval. Extension rods are inserted through the probe rod string and threaded onto the MC Stop-Pin Assembly. When unthreaded, the stop-pin is removed from

the tool string with the extension rods. (MC Piston rod is removed with stop-pin if MC Stop-Pin Coupler is utilized). With the point assembly now released, the tool string is driven into the subsurface to fill the sampler with soil. The point assembly is later retrieved from the sampler with the liner and soil core.

Loose soils may fall from the bottom of the sampler as it is retrieved from depth. The MC Core Catcher (Fig. 3.1) alleviates this problem. Excellent results are obtained when the core catcher is used with saturated sands and other non-cohesive soils. A core catcher should not be used with tight soils as it may actually inhibit sample recovery. Constructed of PVC, the core catcher is suitable for use with all Geoprobe liners.

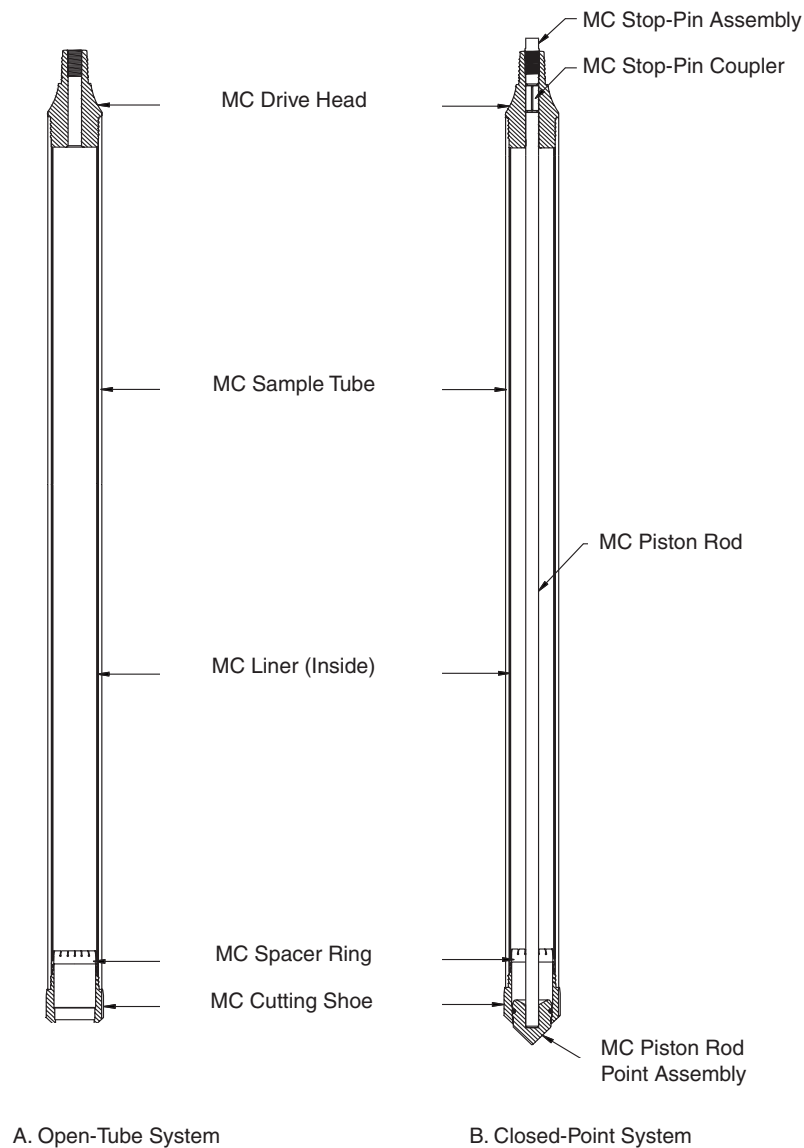
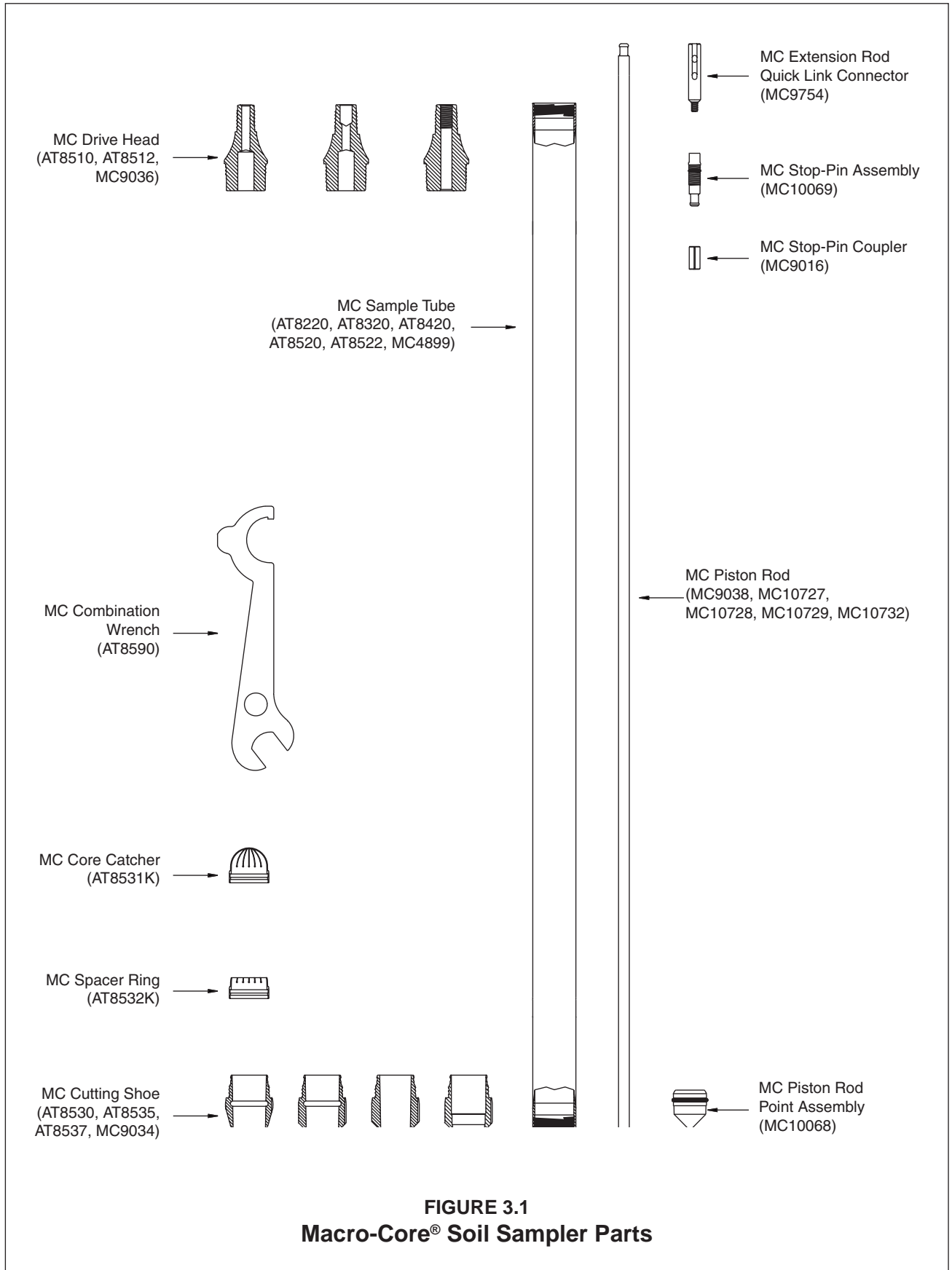

FIGURE 2.1
Macro-Core® Soil Sampler Configurations



3.0 REQUIRED EQUIPMENT

The following equipment is used to recover samples using the Geoprobe Macro-Core® Soil Sampler and probing system. Although many options are available (sampler length, liner material, etc.), the basic sampler configuration does not change. Refer to Figure 3.1 (previous page) to view the major components of the Macro-Core® sampler.

MACRO-CORE® SAMPLER PARTS	PART NUMBER
MC Drive Head, for use with 1.0-inch probe rods	AT8510
MC Drive Head, for use with 1.25-inch probe rods	AT8512
MC Sample Tube, 24-inch, unplated	AT8220
MC Sample Tube, 36-inch, unplated	AT8320
MC Sample Tube, 1-meter, unplated	AT8420
MC Sample Tube, 48-inch, Ni-plated	AT8520
MC Sample Tube, 48-inch, unplated	AT8522
MC Sampler Tube, 60-inch, unplated	MC4889
MC Cutting Shoe, standard	AT8530
MC Cutting Shoe, heavy-duty	AT8535
MC Cutting Shoe, 0.125 inches undersized	AT8537
MC Combination Wrench	AT8590
Nylon Brush for MC Sample Tubes	BU700

MACRO-CORE® PISTON ROD SYSTEM PARTS	PART NUMBER
O-Rings for MC Stop-Pin (pkg. of 25)	AT6312R
O-Rings for MC Piston Rod Point (pkg. of 25)	DT4070R
MC Stop-Pin Coupler (pkg. of 5)	MC9016
MC Cutting Shoe, for use with piston rod point	MC9034
MC Drive Head, for use with 1.25-inch probe rods and stop-pin	MC9036
MC Piston Rod, 48-inch	MC9038
MC Extension Rod Quick Link Connector	MC9754
MC Piston Rod Point Assembly	MC10068
MC Stop-Pin Assembly	MC10069
MC Piston Rod/Stop-Pin Assembly, 48-inch	MC10070
MC Piston Rod, 60-inch	MC10727
MC Piston Rod, 36-inch	MC10728
MC Piston Rod, 24-inch	MC10729
MC Piston Rod, 1-meter	MC10732
MC Piston Rod/Stop-Pin Assembly, 60-inch	MC11881
MC Piston Rod/Stop-Pin Assembly, 36-inch	MC12028
MC Piston Rod/Stop-Pin Assembly, 24-inch	MC12029
MC Piston Rod/Stop-Pin Assembly, 1-meter	MC12030
MC Quick Link Kit	MC12131

MACRO-CORE® LINERS AND ACCESSORIES**PART NUMBER**

MC Stainless Steel Liner Assembly, 48-inch	AT7235
MC Teflon® Liner Assembly, 48-inch	AT724
MC PETG Liner, thin-wall, 48-inch, (box of 66)	AT725K
MC Vinyl End Caps (66 pair)	AT726K
MC Heavy-Duty PETG Liner Assembly, 48-inch (box of 66)	AT825K
MC PVC Liner Assembly, clear, 24-inch (box of 66)	AT922K
MC PVC Liner Assembly, clear, 36-inch (box of 66)	AT923K
MC PVC Liner Assembly, clear, 1-meter (box of 66)	AT924K
MC PVC Liner Assembly, clear, 48-inch (box of 66)	AT925K
MC Liner Cutter Kit	AT8000K
MC Liner Cutting Tool*	AT8010
MC Liner Cutter Holder*	AT8020
MC Liner Cutter Blades (pkg. of 5)*	AT8030
MC Liner Circular Cutting Tool	AT8050
MC Core Catchers (pkg. of 25)	AT8531K
MC Spacer Rings (pkg. of 25)	AT8532K
MC PVC Liner Assembly, clear, 60-inch (box of 66)	11984

GEOPROBE TOOLS****PART NUMBER**

Drive Cap, for use with 1.25-inch probe rods	AT1200
Slotted Drive Cap, for use with 1.25-inch probe rods	AT1202
Pull Cap, for use with 1.25-inch probe rods	AT1204
Probe Rod, 1.25 inches x 36 inches	AT1236
Probe Rod, 1.25 inches x 1 meter	AT1239
Probe Rod, 1.25 inches x 48 inches	AT1248
Probe Rod, 1.25 inches x 60 inches	AT1260
MC Pre-Probe, 2-inch OD	AT1247
MC Pre-Probe, 2.5-inch OD	AT1242
MC Pre-Probe, 3-inch OD	AT1252
Extension Rod, 36-inch	AT67
Extension Rod, 48-inch	AT671
Extension Rod, 1-meter	AT675
Extension Rod Coupler	AT68
Extension Rod Handle	AT69
Extension Rod Quick Links	AT694K
Machine Vise	FA300

ADDITIONAL TOOLS

Combination Wrench, 1/2-inch (or) Adjustable Wrench
Pipe Wrenches (2)

*The items are included in the MC Liner Cutter Kit (AT8000K).

**Geoprobe tools and accessories are also available for use with 1.0-inch OD (outside diameter) probe rods.

4.0 OPERATION

Size and material options have resulted in an extensive list of Macro-Core® part numbers. To simplify the instructions presented in this document, part numbers are listed in the illustrations only. Refer to Pages 6 and 7 for a complete parts listing.

4.1 Decontamination

Before and after each use, thoroughly clean all parts of the soil sampling system according to project requirements. A new, clean liner is recommended for each sample if using PETG, PVC, or Teflon® liners.

Stainless Steel Liners from Geoprobe Systems are cleaned at the factory with an agitated detergent bath at a temperature of approximately 180 degrees F. After rinsing with 180-degree tap water, the liner is air dried, wrapped in PVC outer cladding, and capped with vinyl end caps.

Thoroughly clean the sampler before assembly, not only to remove contaminants but also to ensure correct operation. Dirty threads complicate assembly and may lead to sampler failure. Sand is particularly troublesome as it can bind liners in the sample tube resulting in wasted time and lost samples.

4.2 Field Blank

It is suggested that a field blank be taken on a representative sample liner prior to starting a project and at regular intervals during extended projects. Liners can become contaminated in storage. A field blank will prove that the liners do not carry contaminants which can be transferred to soil samples. The following information is offered as an example method which may be used to take a field blank. Make the appropriate modifications for the specific analytes of interest to the investigation.

Example Procedure:

REQUIRED EQUIPMENT

MC Liner	(1)
MC Vinyl End Caps	(2)
Distilled Water	(100 ml)
VOA Vial (or other appropriate sample container)	(1)

1. Place a vinyl end cap on one end of the liner.
2. Pour 100 milliliters of distilled water (or other suitable extracting fluid) into the liner.
3. Place a vinyl end cap on the open end of the liner.
4. From the vertical position, repeatedly invert the liner so that the distilled water contacts the entire inner surface. Repeat this step for one minute.
5. Remove one end cap from the liner, empty contents into an appropriate sample container, and cap the container.
6. Perform analysis on the extract water for the analytes of interest to the investigation.

4.3 Open-Tube Sampler Assembly

- 1a. **(With MC Core Catcher)** Place the open end of an MC Core Catcher over the threaded end of an MC Cutting Shoe as shown in Figure 4.1. Apply pressure to the core catcher until it snaps into the machined groove on the cutting shoe.

NOTE: AT725K (thin-wall PETG) liners have a swedged end which is generally slipped directly over the groove in the cutting shoe (Fig. 4.2). To use a core catcher with these liners, cut approximately 0.25 inches (6 mm) of material from the swedged end of the liner and proceed to Step 2.

- 1b. **(Without MC Core Catcher)** Push the base of an MC Spacer Ring onto the threaded end of a cutting shoe until it snaps into place (Fig. 4.3).

NOTE: With the exception of AT-725K (thin-wall PETG) liners, all liners must utilize either a spacer ring or core catcher. PETG liners have a swedged end which slides directly over the end of the cutting shoe. Attach the liner to the cutting shoe (Fig. 4.2) before proceeding to Step 2.

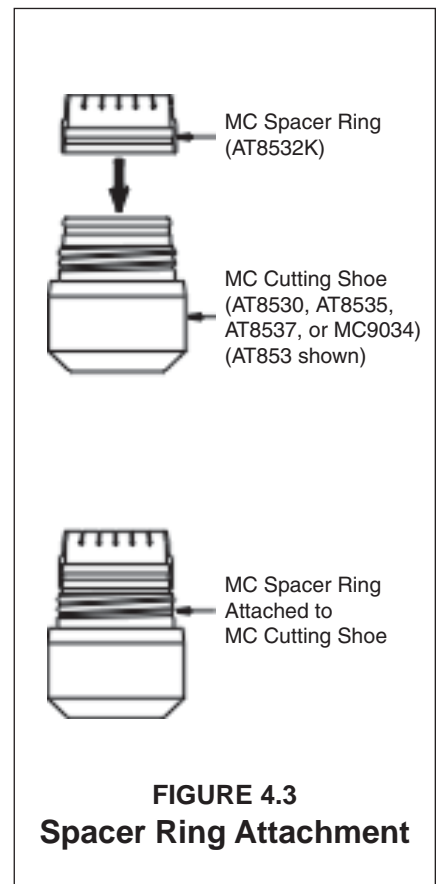
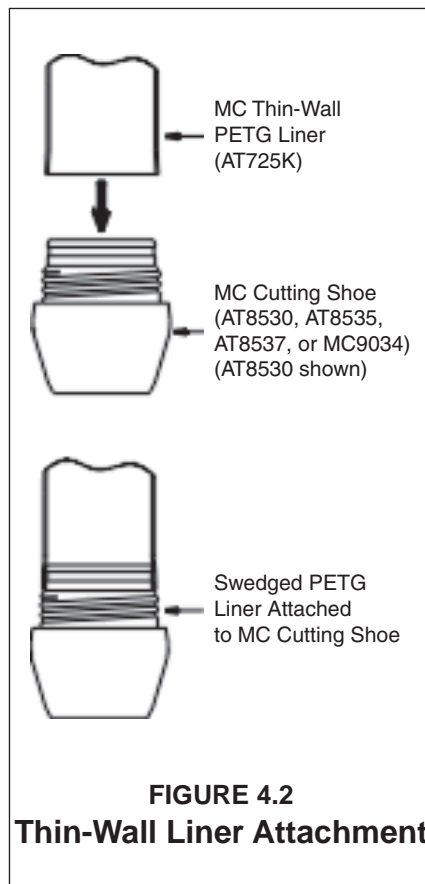
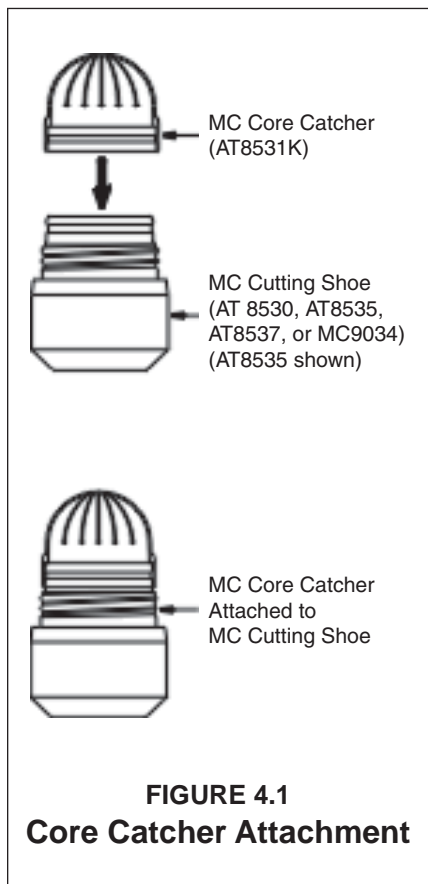

Refer to Figure 4.4 for identification of sampler parts and assembly sequence

2. Thread the cutting shoe into one end of an MC Sample Tube (Fig. 4.5). Tighten shoe with MC Combination Wrench (Fig. 4.6) until end of sample tube contacts machined shoulder of cutting shoe.
3. Insert a liner into the opposite end of the sample tube (Figure 4.7). The liner is all ready installed if using thin-wall PETG liners (AT725K) without an MC Core Catcher.
4. Thread an MC Drive Head into the top of the sample tube (Fig. 4.8) and securely tighten with the MC Combination Wrench (Fig. 4.9). Ensure that the end of the sample tube contacts the machined shoulder of the drive head.

Sampler Assembly is Complete.

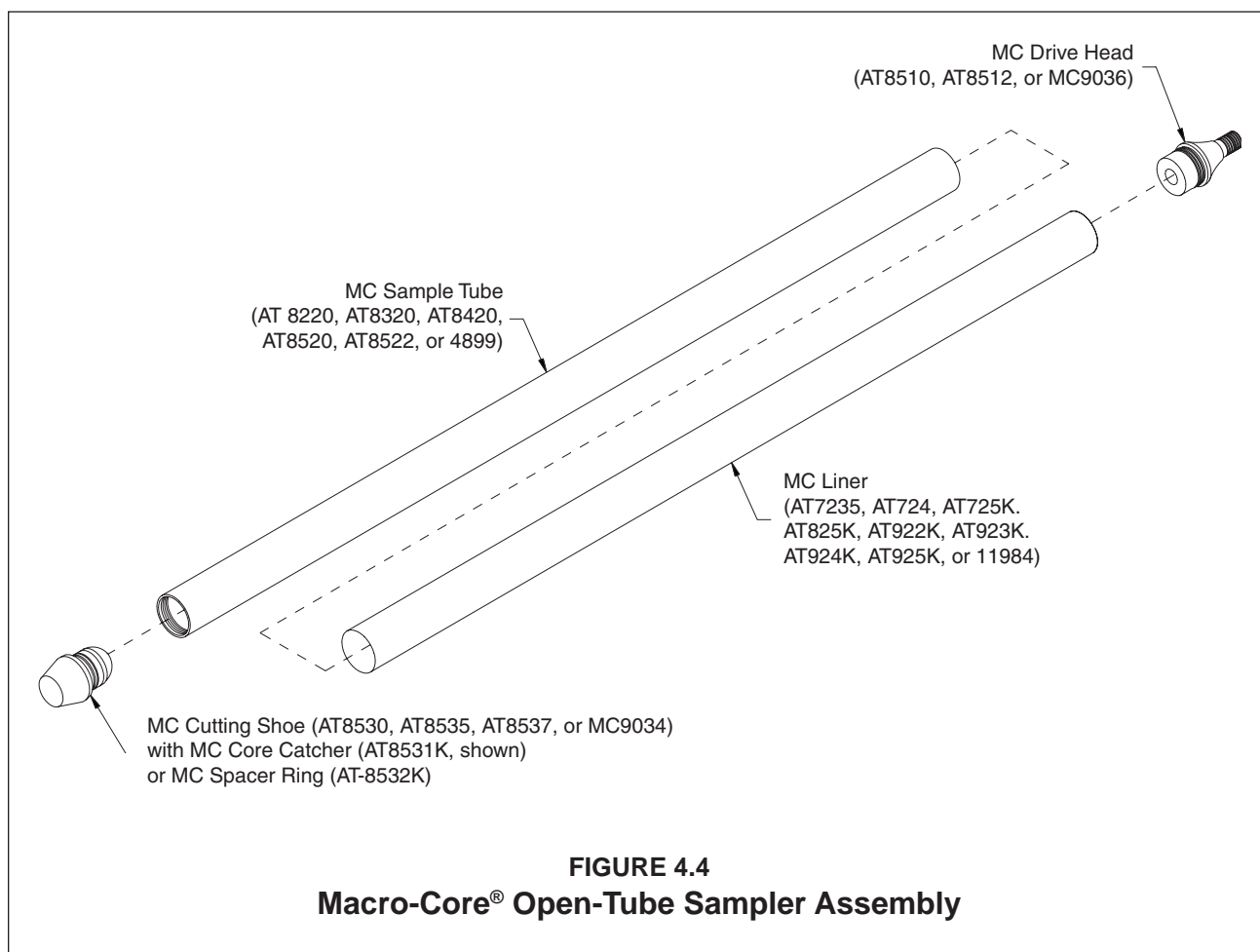



Figure 4.5. Thread an MC Cutting Shoe (shown with MC Core Catcher) into either end of a MC Sample Tube.



Figure 4.6. Tighten MC Cutting Shoe with MC Combination Wrench.



Figure 4.7. Insert liner into opposite end of MC Sample Tube.



Figure 4.8. Thread MC Drive Head into top of MC Sample Tube.

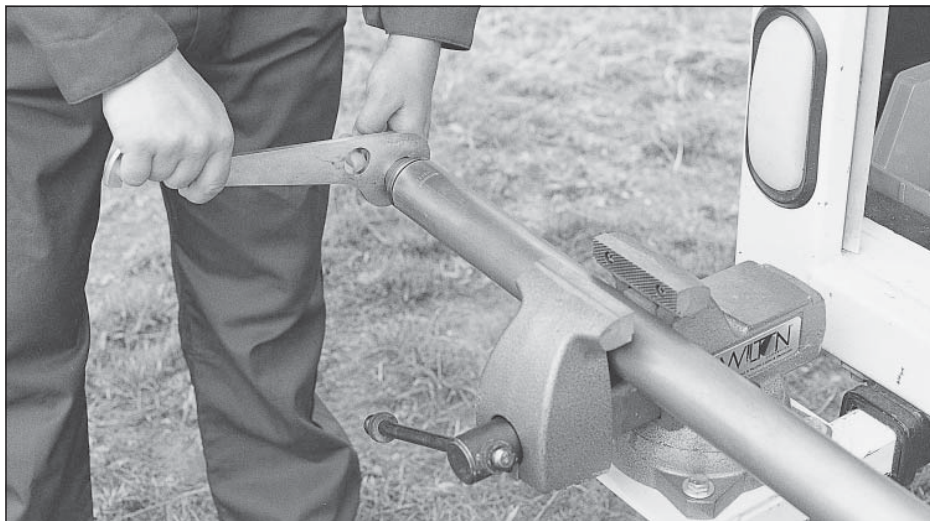

Figure 4.9. Tighten MC Drive Head with MC Combination Wrench. A vise is often used to hold the MC Sample Tube during this step.

4.4 Stop-Pin Coupler

The Stop-Pin Coupler attaches the Stop-Pin to the Piston Rod (Fig. 4.10). When connected together, these three parts form the Stop-Pin/Piston Rod Assembly. All three items may be ordered either individually or together as one complete assembly. Refer to Section 3.0 for specific assembly and item part numbers.

It is not always necessary to use the stop-pin coupler with the MC Piston Rod System. The coupler allows the piston rod to be removed from the sampler along with the stop-pin so that sample recovery is not hindered by the weight of the piston rod. If you find that recovery is not a problem with the formation you are sampling (such as clays), do not use the stop-pin coupler.

If sampling in formations where sample recovery may be a problem (such as loose sands), the stop-pin coupler is highly recommended. Removing the piston rod with the stop-pin significantly reduces the amount of tooling weight that the soil core must support as the sampler is driven. Sample compression is also reduced when the stop-pin coupler is utilized.

Instructions for connecting the stop-pin coupler to the stop-pin and piston rod are given below.

1. Hold a piston rod in vertical position with leading end resting on a solid surface.
2. Place a Stop-Pin Coupler on top of the Piston Rod and tap with a hammer to seat (Fig. 4.11).
3. Snap a Stop-Pin into the coupler using a hammer or 12-inch probe rod and drive cap (Fig. 4.12).

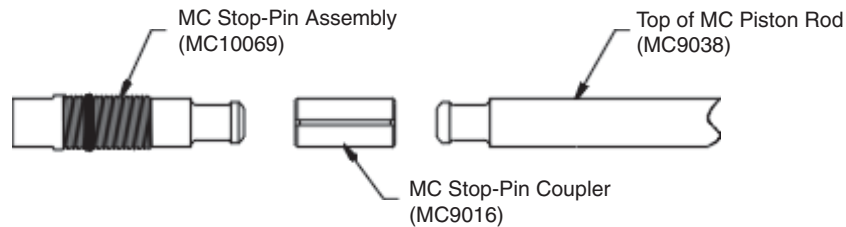
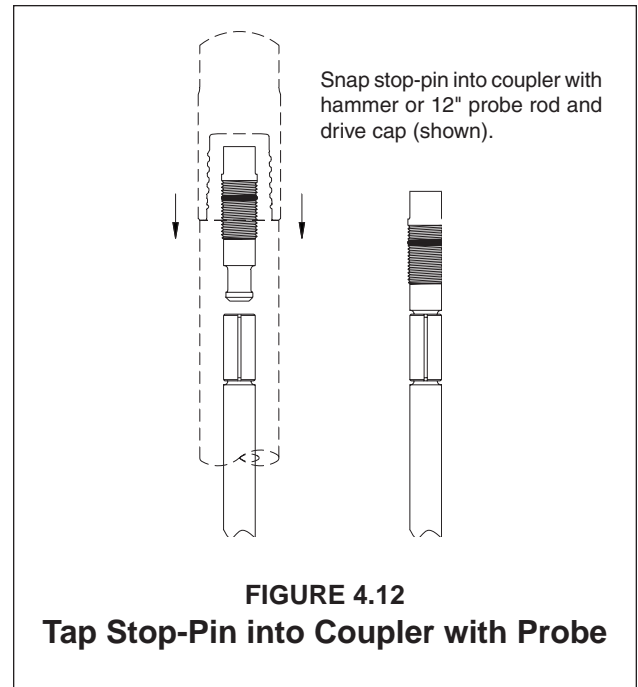
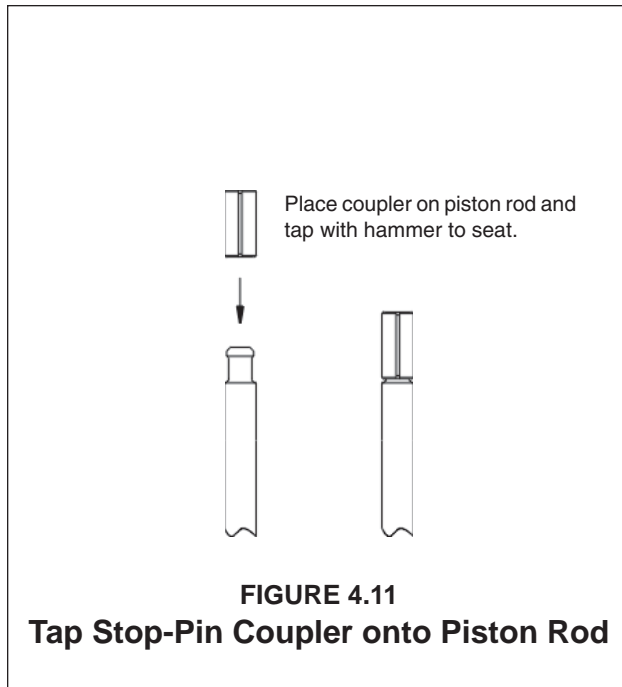

FIGURE 4.10
MC Stop-Pin Coupler Attaches MC Stop-Pin to MC Piston Rod



4.5 MC Piston Rod Sampler (closed-point system) Assembly

The MC Piston Rod System seals the leading end of the sampler with a point assembly that is held in place with a piston rod and stop-pin. Once advanced to the top of the sampling interval, the stop-pin is removed with extension rods that are inserted down through the probe rod string. The piston rod will be extracted along with the stop-pin if a stop-pin coupler was used. Refer to Section 4.4 for help in determining when a stop-pin coupler is needed.

NOTE: The MC Piston Rod System requires an MC9036 MC Drive Head and an MC9034 MC Cutting Shoe. No other Macro-Core® drive heads or cutting shoes are compatible with this system. The larger 1.25-inch OD Probe Rods are also required to operate MC Piston Rod System.

1. Install an O-ring in the machined groove on the piston rod point (Fig. 4.13). Lubricate the O-ring with a small amount of deionized water.

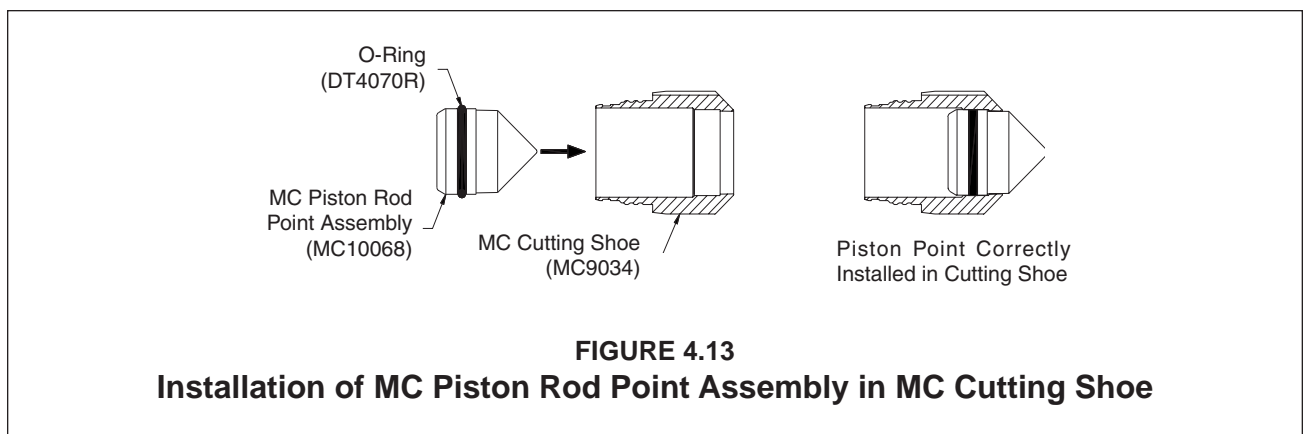

2. Push the piston rod point completely into the cutting shoe as shown in Figure 4.13.
- 3a. **(With MC Core Catcher)** Place the open end of a core catcher over the threaded end of the cutting shoe as shown in Figure 4.14. Apply pressure to the core catcher until it snaps into the machined groove on the cutting shoe.

NOTE: AT725K (thin-wall PETG) liners have a swaged end that is slipped directly over the groove in the cutting shoe (Fig. 4.15). To use a core catcher with these liners, simply cut approximately 0.25 inches (6 mm) of material from the swaged end of the liner and continue to Step 4.

- 3b. **(Without Core Catcher)** Push the base of an MC Spacer Ring onto the threaded end of the cutting shoe until it snaps into place (Fig. 4.16).

NOTE: With the exception of AT725K (thin-wall PETG) liners, all liners must utilize either a spacer ring or core catcher. Thin-wall liners have a swaged end which slides directly over the end of the cutting shoe. If using thin-wall liners, attach the liner to the cutting shoe (Fig. 4.15) before proceeding.

Refer to Figure 4.17 for identification of sampler parts and assembly sequence

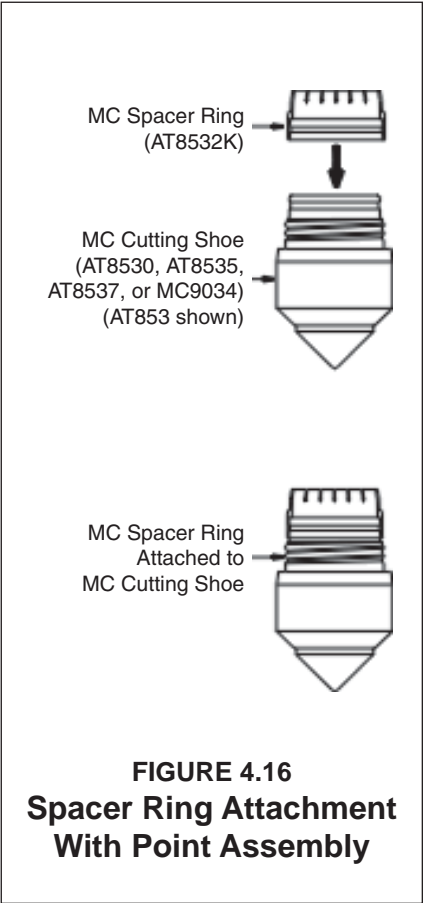
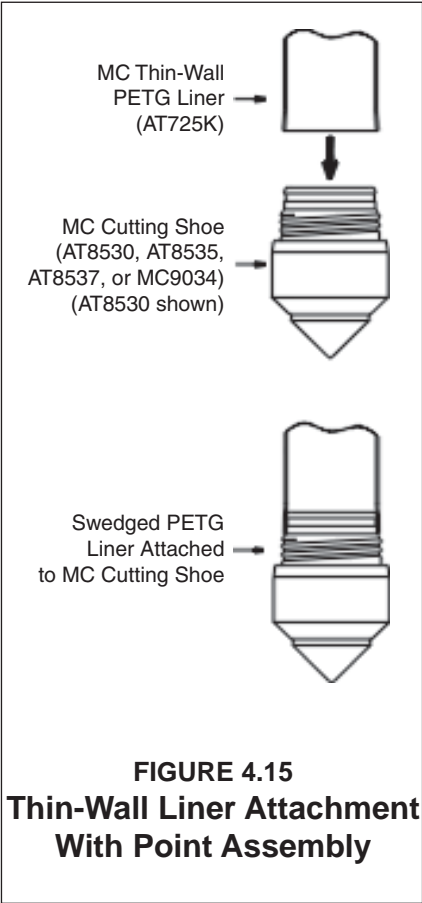
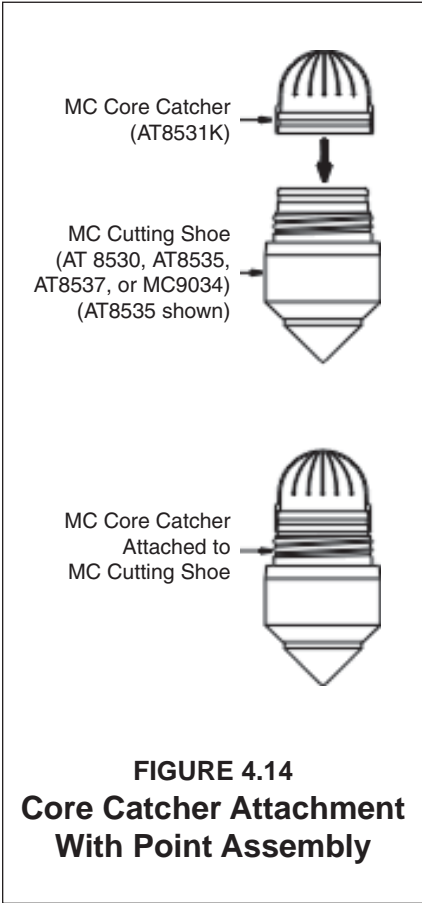

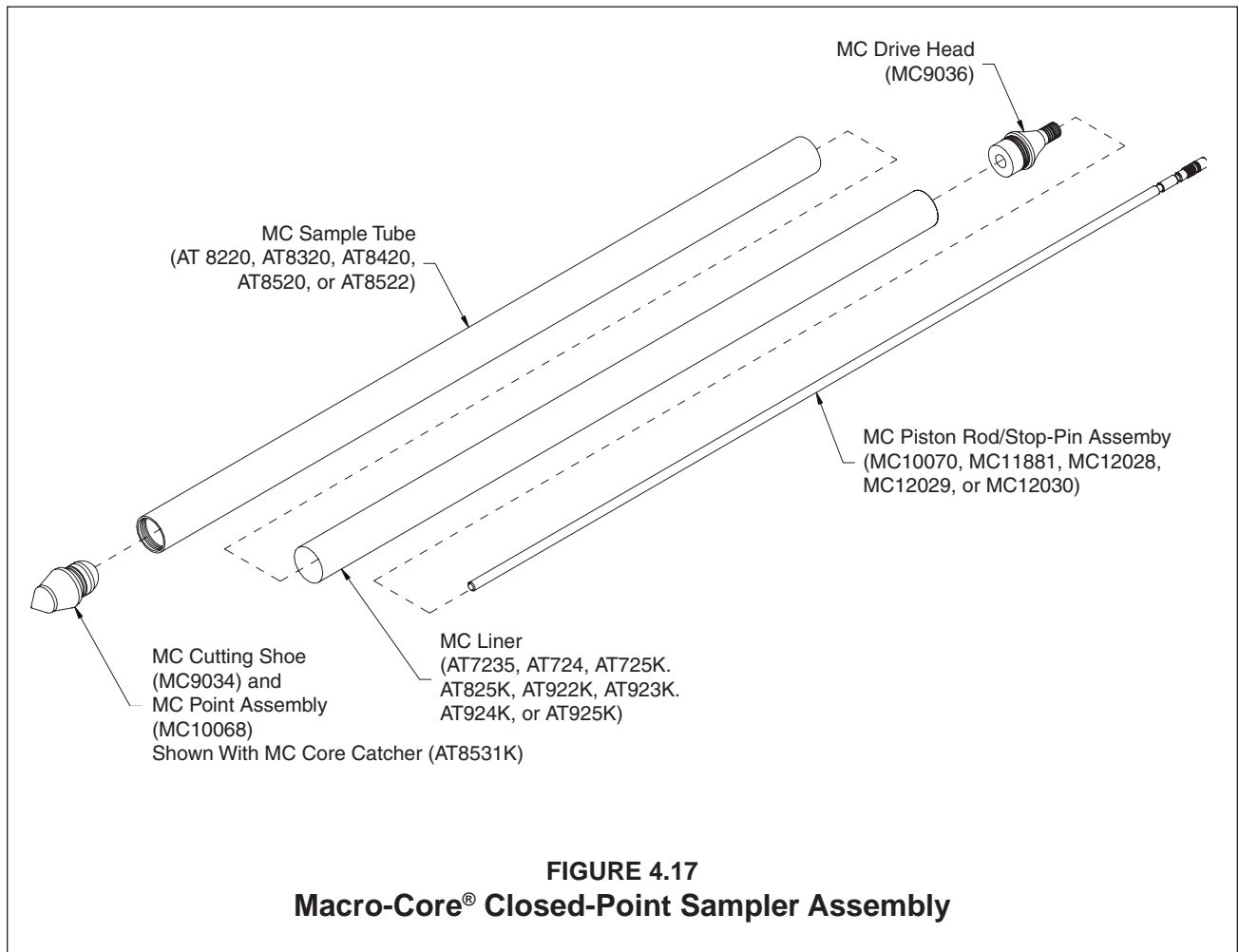

4. Thread the cutting shoe (with point) into one end of an MC Sample Tube. Tighten until the end of the sample tube contacts the machined shoulder of the cutting shoe.
5. Insert an appropriate MC Liner into the sample tube (Fig. 4.18). The liner is all ready installed if using thin-wall PETG liners without a core catcher.
6. Thread an MC Drive Head into the top of the sample tube (Fig. 4.19) and securely tighten with the combination wrench (Fig. 4.20) until the end of the sample tube contacts the machined shoulder of the drive head.

(continued on Page 16)

7. Insert an MC Piston Rod/Stop-Pin Assembly through the drive head until the stop-pin threads contact



Figure 4.18. Insert liner into opposite end of MC Sample Tube.



Figure 4.19. Thread MC Drive Head into top of MC Sample Tube.

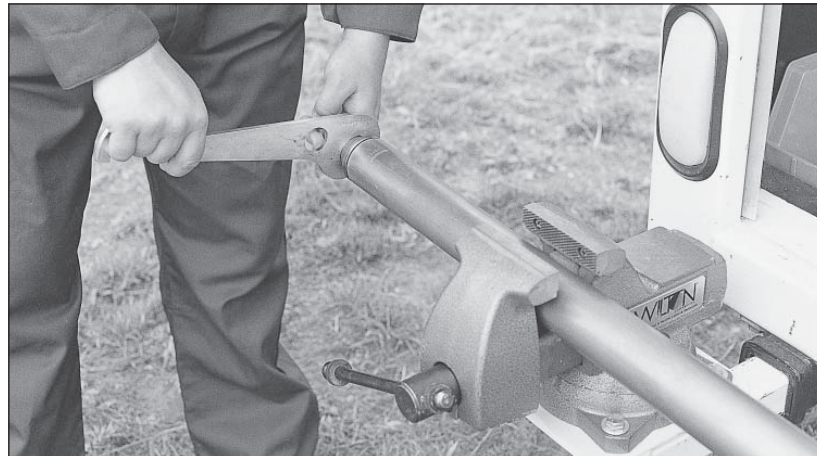

Figure 4.20. Tighten MC Drive Head with MC Combination Wrench. A vise is often used to hold the MC Sample Tube during this step.

the top of the drive head (Fig. 4.21). Ensure that an O-ring has been placed on the stop-pin.

The leading end of the piston rod may hangup on the core catcher during assembly. When this happens, raise the assembly 6-8 inches above the core catcher and then allow the assembly to fall back down into the sampler. This should allow the piston rod to pass through the fingers of the core catcher.

Note: The MC Stop-Pin Coupler may be omitted under certain sampling conditions. Refer to Section 4.4 for information regarding when a coupler is needed and instructions for coupler installation.

8. Thread the stop-pin into the drive head (left-hand threads) with an adjustable or 1/2-inch combination wrench. Fully tighten the stop-pin and then back it off slightly (~10 degrees). This avoids locking the stop-pin threads and allows it to later be unthreaded from the ground surface with extension rods.

Sampler Assembly is Complete.

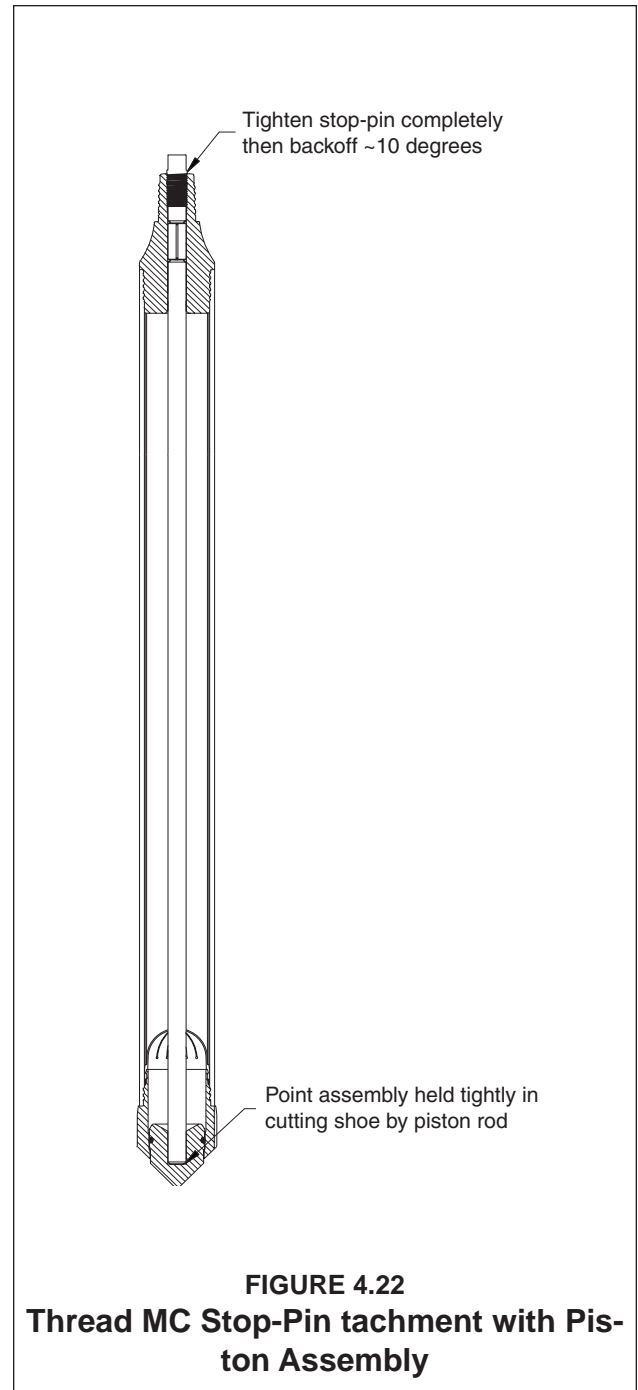
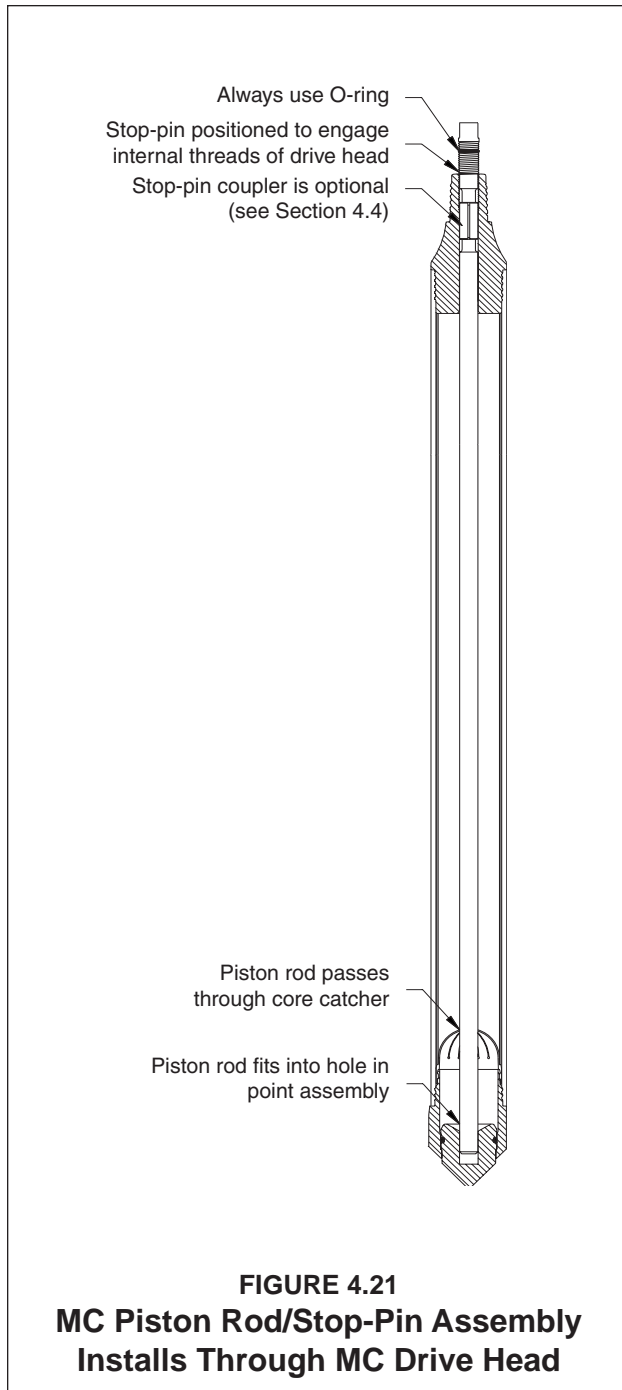

4.6 Pilot Hole

A pilot hole prevents excessive sampler wear in tough soils and saves time when a discrete soil core is desired. The pilot hole is created by driving a 2.0-, 2.5-, or 3.0-inch MC Pre-Probe (see Section 3.0 for part numbers) to the top of the sampling interval. Soil surfaces containing gravel, asphalt, hard sands, or rubble should be pre-probed to reduce wear on the cutting shoe and to avoid damage to the sampler. To save time when collecting a discrete soil core, pre-probe to the sampling interval rather than coring to depth with the sampler.

4.7 Open-Tube Sampling

The Macro-Core® Open-Tube Sampler is used to gather continuous soil cores beginning from ground surface. A representative soil sample is obtained by driving the assembled sampler one sampling interval into the subsurface through undisturbed soil. Upon retrieving the sampler, the liner and soil core are removed. The sampler is then properly decontaminated, reassembled with a new liner, and inserted back down the same hole to collect the next soil core.

Instructions for operation of the Open-Tube Macro-Core® Sampler are given in this section.

1. Thread a Drive Cap (AT1200) onto the drive head of an assembled Open-Tube Macro-Core® Sampler as shown in Figure 4.23. (Refer to Section 4.3 for sampler assembly).
2. Raise the probe unit hammer assembly to its highest position by fully extending the probe cylinder.
3. Position the MC Sampler for driving as shown in Figure 4.24. Place the sampler directly under the hammer with the cutting shoe centered between the toes of the probe foot. The sampler should now be parallel to the probe derrick. Step back from the unit and visually check sampler alignment.
4. Apply static weight and hammer percussion to advance the sampler until the drive head reaches the ground surface (Fig. 4.25A)

NOTE: Activate hammer percussion whenever collecting soil. Percussion helps shear the soil at the leading end of the sampler so that it moves into the sample tube for increased recovery.

5. Raise the hammer assembly a few inches to provide access to the top of the sampler.
6. Remove the drive cap and thread a Pull Cap (AT1204) onto the sampler drive head.
7. Lower the hammer assembly and hook the hammer latch over the pull cap (Fig. 4.26). Raise the hammer assembly to pull the sampler completely out of the ground.
8. Proceed to Section 4.9 for instructions on recovering the soil core from the MC Sampler.

To sample consecutive soil cores, advance a clean sampler down the previously opened hole (Fig. 4.25B) to the top of the next sampling interval (Fig. 4.25C). Drive the tool string the length of the sampler to collect the next soil core (Fig. 4.25D). Switch to an MC Piston Rod Sampler if excessive side slough is encountered.

NOTE: Use caution when advancing or retrieving the sampler within an open hole. Low side friction may allow the sampler and probe rods to drop down the hole when released. To prevent equipment



Figure 4.23. Thread drive cap onto sampler drive head.



Figure 4.24 MC Sampler positioned for driving into subsurface.



Figure 4.26. Hook hammer latch onto pull cap.

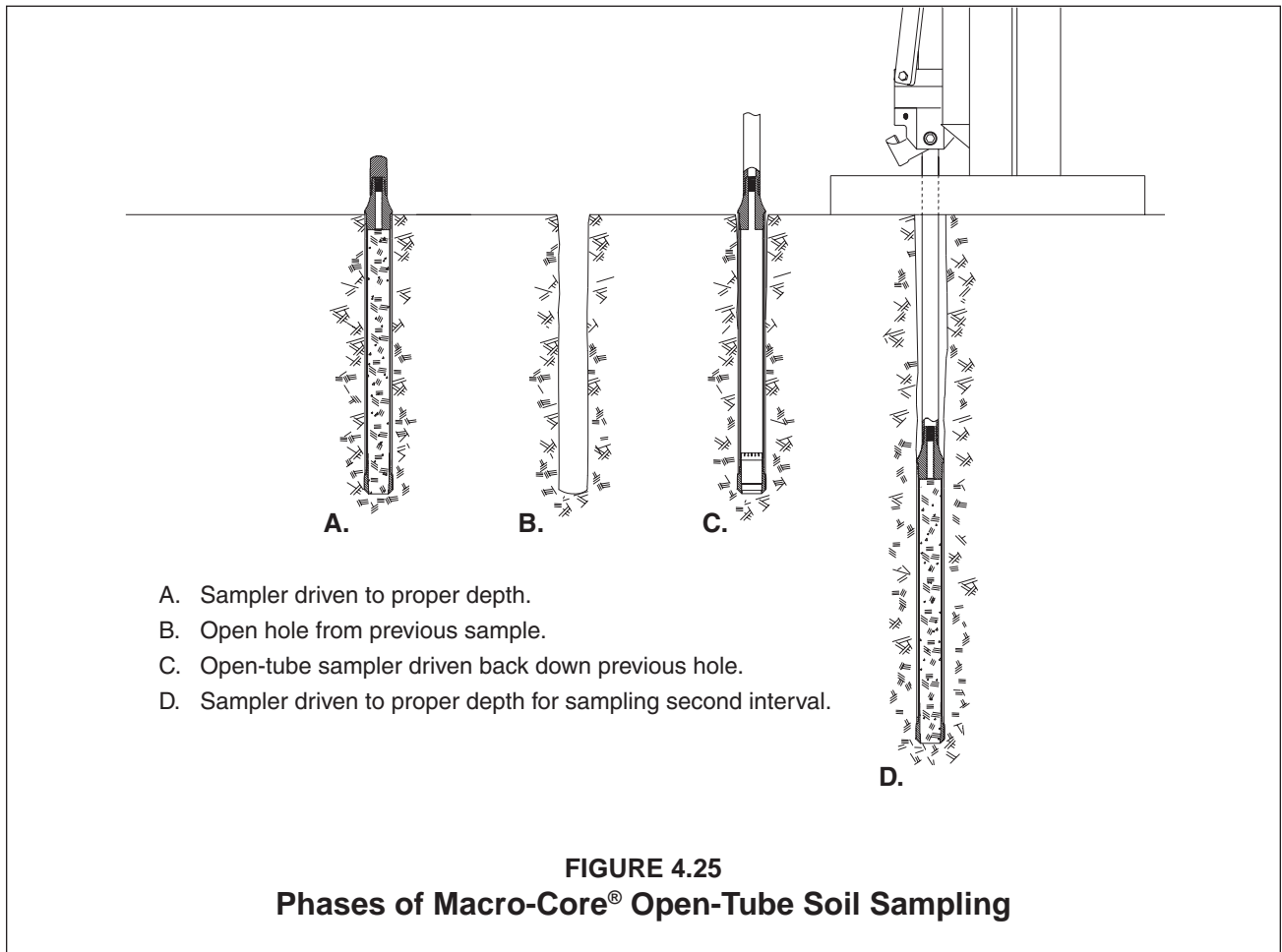

4.8 Closed-Point Sampling with the MC Piston Rod System

Material collapsing from the probe hole sidewall can make it difficult to collect representative soil cores from significant depths with an open-tube sampler. To overcome this problem, the Macro-Core® Sampler can be equipped with a point assembly that is held tightly in the cutting shoe with a piston rod and threaded stop-pin. This allows the sealed sampler to pass through the slough material and then opened at the appropriate sampling interval. Instructions for sampling with the MC Piston Rod System are given in this section.

NOTE: The MC Piston Rod System is designed for continuous core sampling. A probe hole must be opened above the sampling interval either by removing soil with an open-tube Macro-Core® Sampler or by preprobing to depth. Never drive the MC Piston Rod System through undisturbed soil.

1. Attach a Slotted Drive Cap (AT1202) to the drive head of an assembled MC Piston Rod Sampler as shown in Figure 4.27. (Refer to Section 4.5 for sampler assembly.)

NOTE: The MC Stop-Pin extends slightly from the top of the MC Drive Head. A slotted drive cap is therefore required to allow room for the stop-pin (Fig. 4.27). A standard drive cap may be used once probe rods are added to the tool string.

2. Raise the probe unit hammer assembly to its highest position by fully extending the probe cylinder.
3. Place the leading end of the MC Sampler into the **previously opened hole** (Fig. 4.28A).
4. Advance the sampler down the open hole for the full stroke of the probe machine.

NOTE: Use caution when advancing the sampler down an open hole. Low side friction may allow the sampler and probe rods to drop down the hole when released. To prevent equipment loss, hold onto the tool string with a pipe wrench when needed.

5. Remove the slotted drive cap and thread a probe rod onto the MC Drive Head. Thread a standard Drive Cap (AT1200) onto the probe rod.
6. Continue advancing the sampler and adding probe rods to the tool string until the desired sampling interval is reached (Fig. 4.28B).
7. Raise the hammer assembly and retract the probe derrick to gain access to the top probe rod.
8. Remove the drive cap and insert extension rods down the inside of the probe rod string. A male Extension Rod Quick Link and an MC Extension Rod Quick Link Connector should be placed on the leading end of the extension rod string (Fig. 4.29) if an MC Stop-Pin Coupler was used during assembly. Nothing is placed on the leading extension rod if a stop-pin coupler was not used.

Use Extension Rod Couplers or Extension Rod Quick Links (Fig. 4.30) to connect extension rods together until the leading rod contacts the stop-pin. Use an Extension Rod Jig (Fig. 4.30) to hold the down-hole rods while adding more rods to the string.

9. Attach an Extension Rod Handle (Fig. 4.30) to the rod string and slowly rotate the handle clockwise to engage the stop-pin threads. The rods will become harder to turn when the stop-pin threads are fully engaged. Pull up on the rod string to ensure that it is connected to the stop-pin. Continue rotating and periodically lifting the extension rods until the stop-pin is completely unthreaded from the drive head.

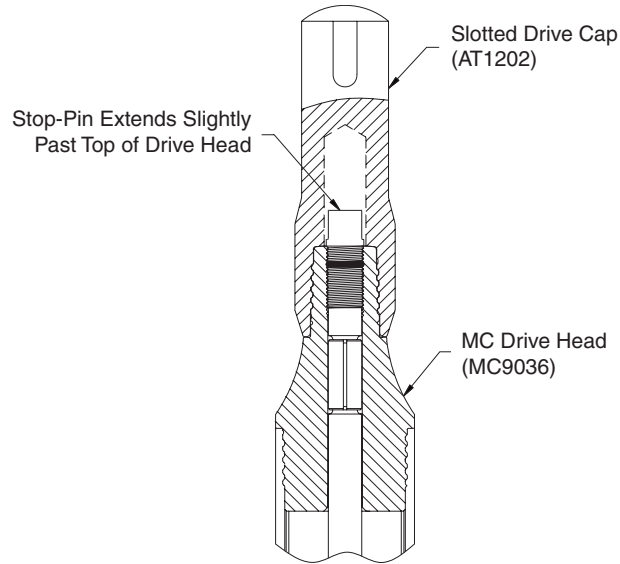

FIGURE 4.27
Slotted Drive Cap Accomodates Stop-Pin

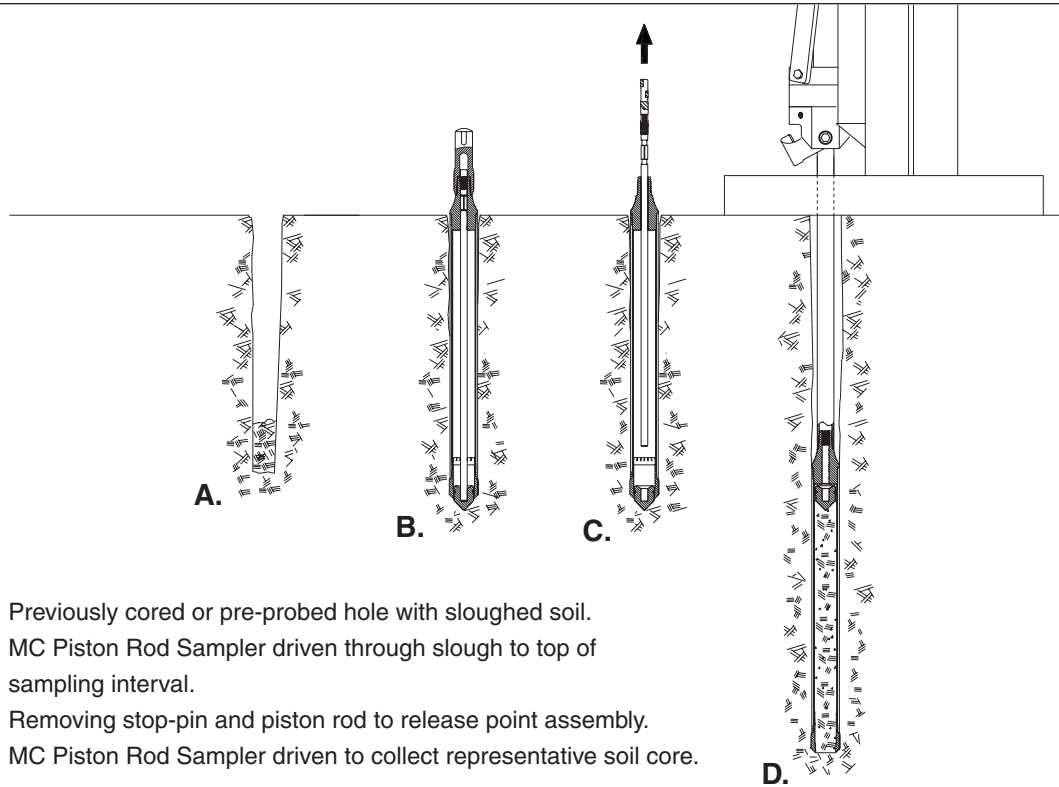

FIGURE 4.28
Phases of Macro-Core® Closed-Point (Piston Rod System) Sampling

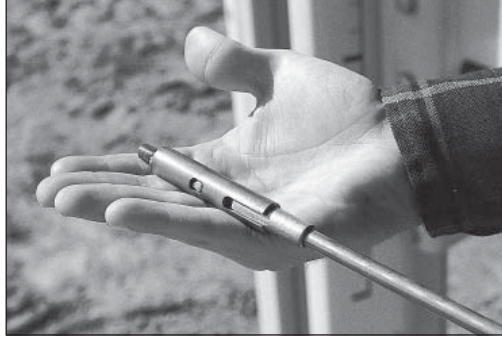

Figure 4.29. Use an MC Extension Rod Quick Link Connector if stop-pin coupler was used in sampler.

NOTE: If the stop-pin is excessively difficult to unthread, pull the entire tool string up approximately 2 inches. This should relieve the force exerted on the point assembly and make releasing the stop-pin much easier.

10. Lift and remove extension rods until the stop-pin is visible above the drive head (Fig. 4.28-C). The stop-pin and piston rod will both be removed from the sampler if a stop-pin coupler was used during assembly (Fig. 4.31-A). Only the stop-pin will be connected to the last extension rod if a coupler was not used (Fig. 4.31-B). Remove the extension rod and stop-pin if the piston rod is not attached.
11. If the piston rod is attached to the stop-pin, carefully unhook the extension rod and male quick link from the MC Extension Rod Quick Link Connector (Fig. 4.31-A). Take care not to deform the stop-pin coupler when removing the extension rod. Now remove the piston rod from inside the tool string.
12. Thread the Drive Cap (AT1200) onto a probe rod and then attach the probe rod to the tool string.
13. Completely raise the probe unit hammer assembly and reposition the probe derrick over the tool string.
14. Apply static weight and hammer percussion to advance the tool string the length of the sampler and collect the soil core (Fig. 4.28-D).

NOTE: Activate hammer percussion whenever collecting soil. Percussion helps shear the soil at the leading end of the sampler so that it moves into the sample tube for increased recovery.

15. Raise the hammer assembly a few inches to provide access to the top of the tool string.
16. Remove the drive cap and thread a Pull Cap (AT1204) onto the top probe rod.
17. Lower the hammer assembly and hook the hammer latch over the pull cap. Raise the hammer assembly to pull the first probe rod out of the ground. Remove the rod and place the pull cap on the next rod of the tool string. Continue pulling probe rods until the MC Sampler is brought to the ground surface.

NOTE: Use caution when retrieving the MC Sampler from depth. Low side friction may allow the sampler and probe rods to drop down the hole when released. To prevent equipment loss, hold onto the tool string with a pipe wrench when needed.

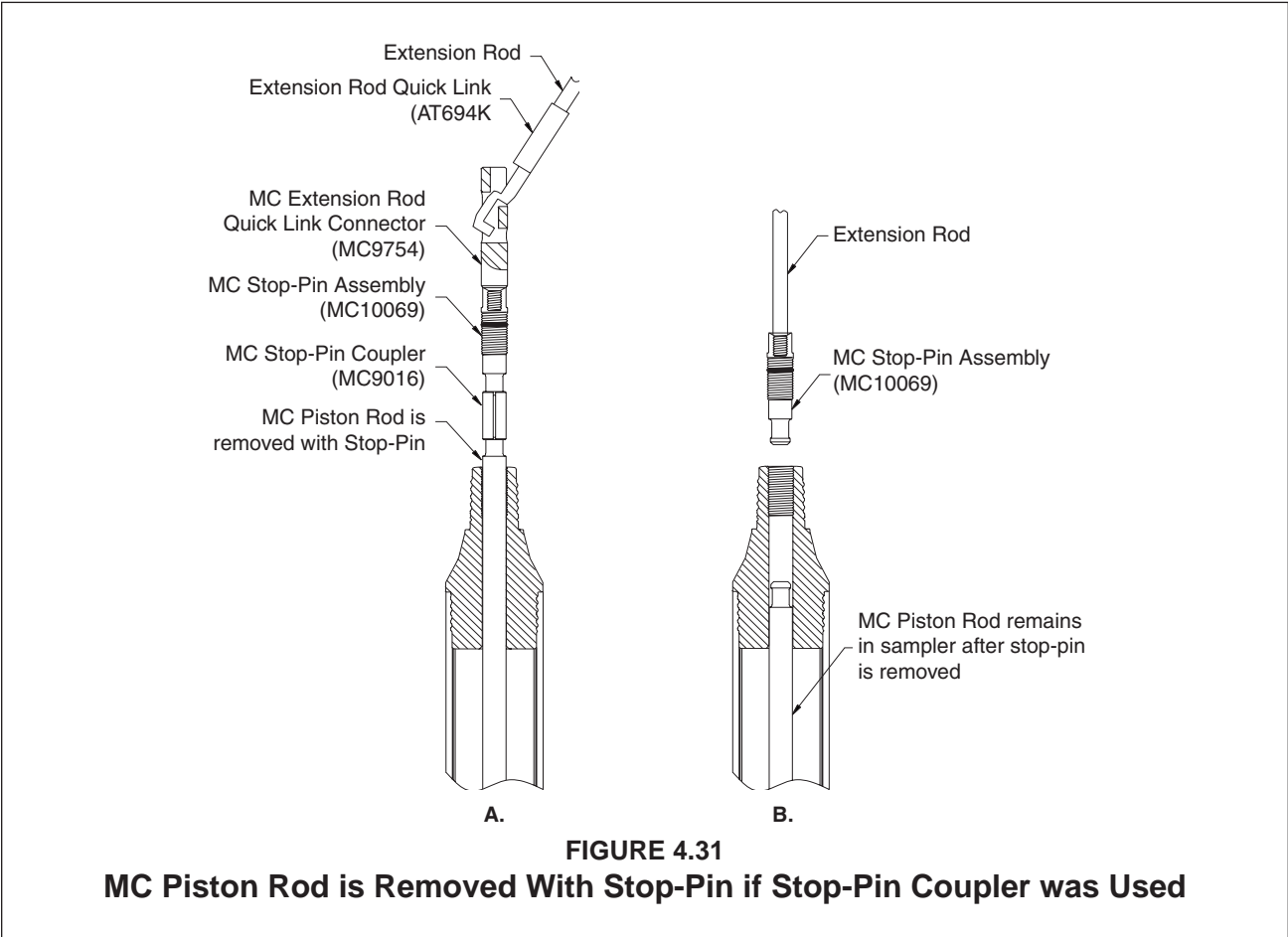
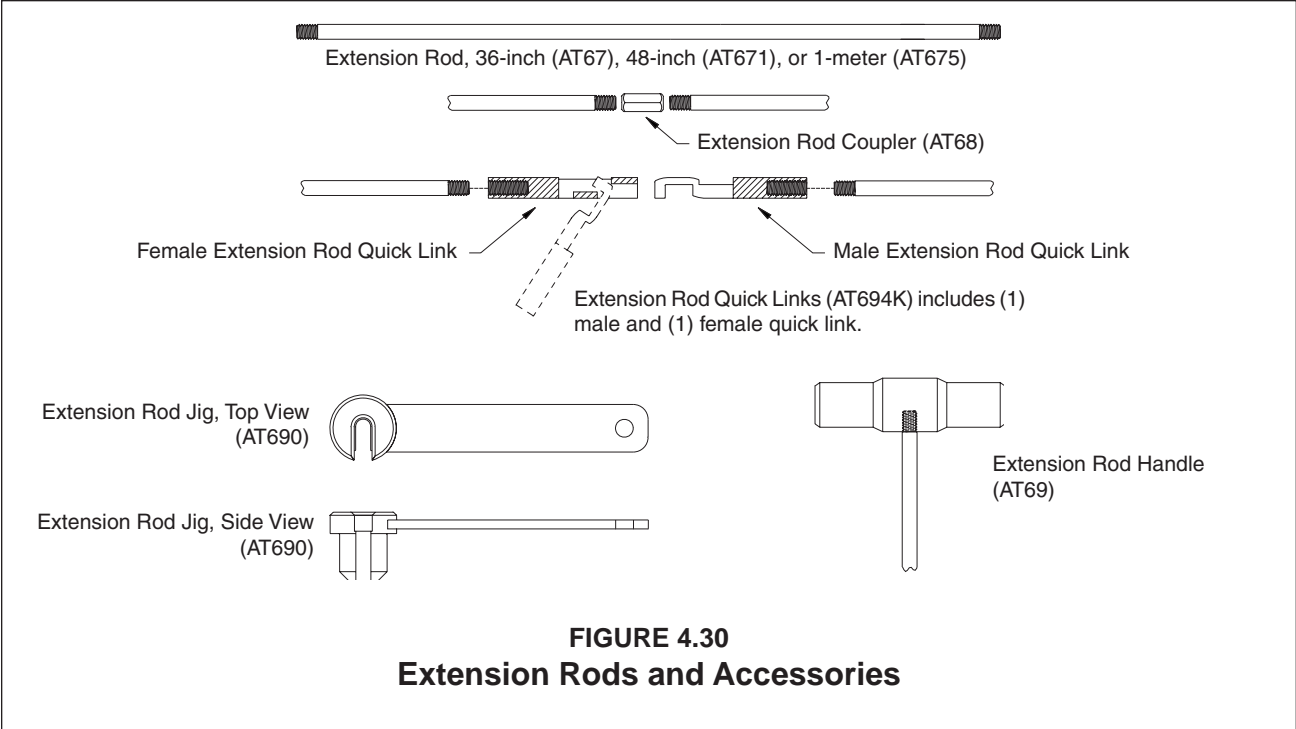

4.9 Soil Core Recovery

The soil sample is easily removed from the Macro-Core® Sampler by unthreading the cutting shoe and pulling out the liner. A few sharp taps on the cutting shoe with the combination wrench will often loosen the threads sufficiently to allow removal by hand. If needed, the exterior of the cutting shoe features a notch for attaching the combination wrench to loosen tight threads (Fig. 4.32). With the cutting shoe removed (Fig. 4.33), simply pull the liner and soil core from the sample tube (Fig. 4.34).

If the closed-point sampler is used, the MC Piston Rod Point Assembly is now retrieved from the end of the liner (Fig. 4.35). Secure the soil sample by placing a vinyl end cap on each end of the liner.

Undisturbed soil samples can be obtained from Teflon®, PVC, and PETG liners by splitting the liner. Geoprobe offers two tools for cutting sample liners. The MC Liner Cutter Kit (AT8000K) is used to make longitudinal cuts in the liner and includes a tool that holds the liner for cutting (Fig. 4.36). The MC Liner Circular Cutting Tool (AT8050) is used to segment the liner by cutting around the outside circumference of the liner (Fig. 4.37).



Figure 4.32. Loosening the MC Cutting Shoe with the MC Combination



Figure 4.33. Removing MC Cutting Shoe and liner from MC Sampler Tube.



Figure 4.34. Macro-Core® liner filled with soil core.



Figure 4.35. MC Piston Rod Point Assembly is retrieved from top of liner.

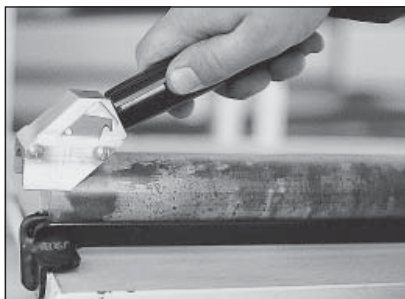

Figure 4.36. MC Liner Cutter makes two longitudinal cuts in polymer liners.

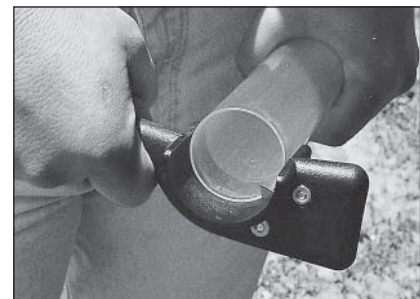

Figure 4.37. MC Circular Cutting Tool cuts around the outside of MC liner.

4.10 MC Piston Rod Sampler Tips

Macro-Core® Samplers are available in lengths of 24 inches, 36 inches, 1 meter, 48 inches, and 60 inches. This means that MC Sample Tubes, MC Liners, MC Piston Rods and MC Piston Rod/Stop-Pin Assemblies are also available in these five sizes. Keep this in mind when ordering Macro-Core® parts to ensure that the items you receive are of the appropriate length.

During development of the MC Piston Rod System, it was common for operators to remove the MC Piston Rod/Stop-Pin assembly from inside the probe rods with the last extension rod still threaded onto the stop-

pin. The MC Stop-Pin Coupler is not designed to withstand the considerable side load placed on it by the extension rod and is easily damaged if the extension rod is allowed to swing around unsupported. The MC Quick Link Connector was developed to prevent damage to the coupler by allowing the last extension rod to be disconnected from the piston rod/stop-pin assembly before removing the assembly from the probe rods. Always use the quick link connector whenever the sampler is assembled with a stop-pin coupler.

4.11 Tips to Maximize Sampling Productivity

The following suggestions are based on the collective experiences of Geoprobe operators:

1. Organize your truck or van. Assign storage areas to all tools and equipment for easy location. Transport sample tubes, piston rods, extension rods, probe rods, and liners in racks. Above all, minimize the number of items lying loose in the back of the vehicle.
2. Take three or four samplers to the field. This allows the collection of several samples before stopping to clean and decontaminate the equipment. A system is sometimes used where one individual operates the probe while another marks the soil cores and decontaminates the used samplers.
3. A machine vise is recommended. With the sampler held in a vise, the operator has both hands free to remove the cutting shoe (Fig. 4.38), drive head, and sample liner (Fig. 4.39). Cleanup is also easier with both hands free. Geoprobe offers an optional Machine Vise (FA300) that mounts directly on the probe derrick (Fig. 4.40).
4. Extension Rod Quick Links (Fig. 4.41) are real time savers. A good method for deploying extension rods is to assemble sections of up to three rods using threaded connectors. Each section is then connected with Quick Links so that up to three rods can be added or removed from the string at once.



Figure 4.38. Removing MC Cutting Shoe with sample tube held in machine vise.



Figure 4.39. Removing filled liner with sample tube held in machine vise.



Figure 4.40. Machine vise mounted directly on Geoprobe Soil Probing Unit.



Figure 4.41. Using Extension Rod Quick Links to connect Extension Rods.

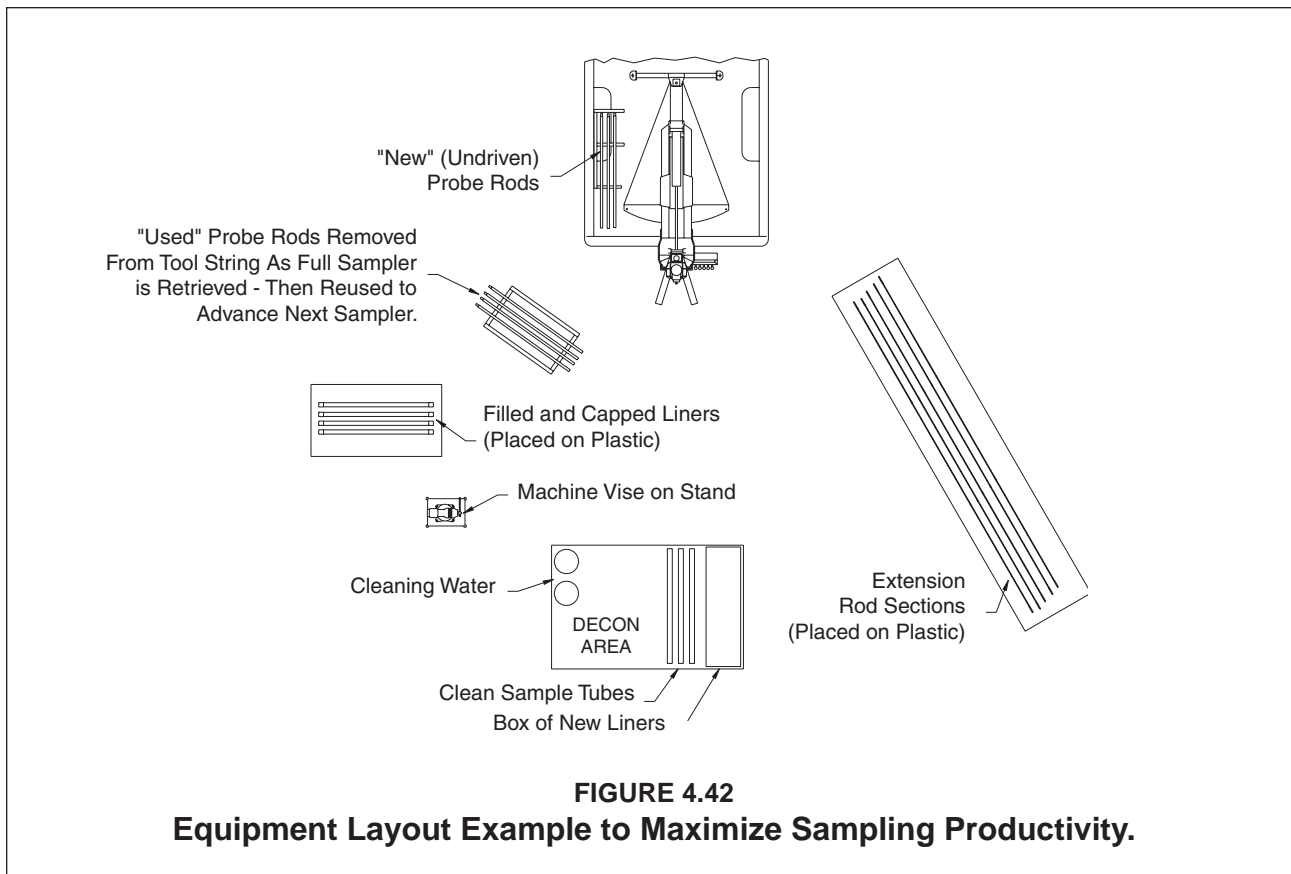

5. When releasing the stop-pin, a pair of locking pliers can be used to turn the extension rods. Locking pliers may be quicker and easier to install than the extension rod handle.
6. Organize your worksite. Practice with the sampler to identify a comfortable setup and then use this layout whenever sampling. An example layout is shown in Figure 4.42.

A collapsible table or stand is handy to hold decontaminated sampler tubes and liners. Equipment may also be protected from contamination by placing it on a sheet of plastic on the ground.

Instead of counting probe rods for each trip in-and-out of the probe hole, identify separate locations for "new" rods and "used" rods. Collect the first sample from the open hole using "new" rods. As each probe rod is removed during sampler retrieval, place it in the "used" rod location. Now advance a clean sampler back down the same hole using all of the rods from the "used" location. Add one "new" rod to the string and then drive the tools to collect the next soil core. Once again, remove each probe rod and place it in the "used" rod location as the sampler is retrieved. Repeat this cycle using all the "used" rods to reach the bottom of the probe hole, and one "new" rod to fill the sampler.

7. Cleanup is very important from the standpoint of operation as well as decontamination. Remove all dirt and grit from the threads of the drive head, cutting shoe, and sample tube with a nylon brush (BU700). Without sufficient cleaning, the cutting shoe and drive head will not thread completely onto the sample tube. The threads may be damaged if the sampler is driven in this condition.

Ensure that all soil is removed from inside the sample tube. Sand particles are especially troublesome

as they can bind liners in the sampler. Full liners are difficult to remove under such conditions. In extreme cases the soil sample must be removed from the liner before it can be freed from the sample tube.

8. Although MC Drive Heads are available for open-tube sampling with 1.0-inch OD probe rods, 1.25-inch rods are recommended for the Macro-Core® Sampler. The larger rod diameter limits downhole deflection of the tool string and ultimately provides a more durable system. The double-lead thread design also makes the 1.25-inch rods thread together faster than previous 1-inch probe rods.
9. The Heavy-Duty MC Cutting Shoe (AT8535) is machined with more material at the critical wear areas. It can be used in place of the Standard MC Cutting Shoe (AT8530) and is designed to lengthen service life under tough probing conditions.

Expansive clays and coarse sands can "grab" and collapse liners as the sample tube is filled with soil. A 1/8-inch Undersized MC Cutting Shoe (AT8537) helps alleviate this problem. The smaller core (1.375 inches OD) allows expanding clays and coarse sands to travel past the liner without binding.

The standard, heavy-duty, and undersized cutting shoes will not accept the MC Piston Rod Point Assembly (MC10068). Only the MC9034 cutting shoe is compatible with the MC Piston Rod System.

10. Maximize the thread life of the sample tube by varying the ends in which the drive head and cutting shoe are installed. The dynamic forces developed while driving the sampler are such that the threads at the drive head wear more quickly than at the cutting shoe. Regularly switching ends will maintain relatively even wear on the sample tube.

5.0 REFERENCES

Geoprobe Systems, September, 1997, "97-98 Tools and Equipment Catalog."

Geoprobe Systems, May, 1995, "1995-96 Tools and Equipment Catalog."

Equipment and tool specifications, including weights, dimensions, materials, and operating specifications included in this brochure are subject to change without notice. Where specifications are critical to your application, please consult Geoprobe Systems.

COPYRIGHT© 1995, 1996, 1997, 1998 by Kejr, Inc.
ALL RIGHTS RESERVED.

No part of this publication may be reproduced or transmitted in any form or by any means, electronic or mechanical, including photocopy, recording, or any information storage and retrieval system, without permission in writing from Kejr Engineering, Inc.



A DIVISION OF KEJR, INC.

Corporate Headquarters

601 N. Broadway • Salina, Kansas 67401 • 1-800-GEOPROBE (1-800-436-7762) • Fax (785) 825-2097

Eastern Regional Office

Lewes, Delaware • (302) 645-0550 • Fax (302) 645-6054

Southcentral Regional Office

Gonzales, Louisiana • (504) 647-3139 • Fax (504) 644-2815

Southeastern Regional Office

Palm City, Florida • (561) 286-1566 • Fax (561) 286-2035

Western Regional Office

Reedley, California • (209) 637-1696 • Fax (209) 637-1796