

# Geoprobe® 150GT Geotech Rig

Geotech Rigs | 150GT

## Geotechnical sampling – Powerful, Fast, Easy, Safe

Specifically designed for customers focused on traditional geotechnical drilling applications utilizing: hollow stem auger, solid stem auger, SPT, mud rotary, air rotary, and high speed coring.

### Telescoping Winch Mast

- Allows tripping out of 20 ft. lengths of rod when combined with 3 ft. extension
- 6,800 lb. primary winch
- 1,800 lb. secondary winch with quick change hook

### CB5 4-Speed Head

- 5,500 ft-lb torque; 600 rpm. (Torque to spin augers, speed to high speed core)
- 6.25 in. external drive for HSA
- Top swivel with 2.5 in. float and 2 3/8 in. API output.

### Drill Mast

- 144 in. of head feed travel and 45 in. of drill mast dump. (This easily gives you the range you need to work ground level, above a pan or drill at an angle.)
- Drill mast utilizes rollers instead of slides
- Easily adjust to hole misalignment with extend and swing

### 26 in. of Head Side Shift

**No CDL\***  
**Required!**  
(\*Class A/B)

### Hands-Free Automatic Drop Hammer

- On independent feed with 73 in. of travel

### High Capacity Hydraulics

- Powered off truck engine
- Saves weight and space

### Mud Pumps

- Multiple configurations available

### Control Panel

- Simple manual controls with operator feedback (weight on bit, rotation RPM, engine diagnostics)

### Swing Out 7 in. Breakout





## Weight & Dimensions

Base Unit Weight: 17,800 lb. (8,074 kg.)  
 With Typical Options: 18,780 lb. (8,518 kg.)

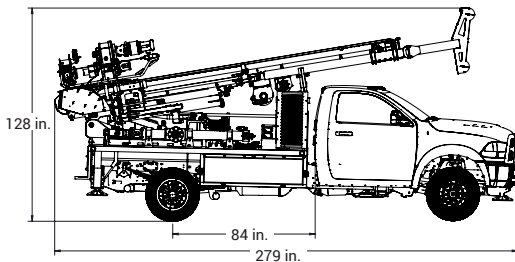
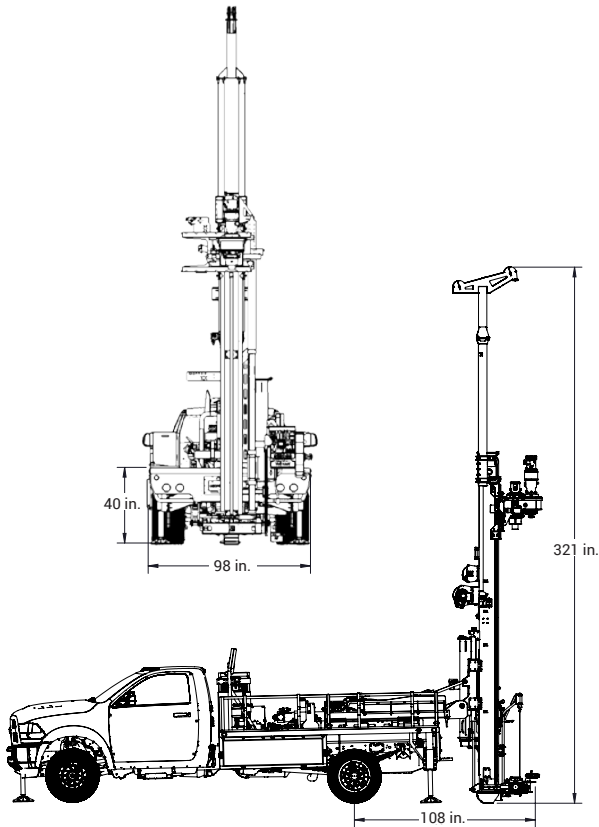

View full specifications online at  
[geoprobe.com/150gt](http://geoprobe.com/150gt)

## Tooling

### Typical Geoprobe® Tooling for the 150GT

- SPT Sampling (Interlocking Split Spoon Sampler, Dual Tube with 1.75 in. or AWJ Center Rods, 3.25 HSA, 4.5 in. Solid Auger, Mud Rotary)
- NWL Wireline System
- HSA System (4.25 in. and 6.25 in.)

\*Center Rod Use Only

Rig shown with optional features. Weights & dimensions subject to change without notice.

## 150GT Options

### Head Options

231236 4 Speed Combo Head (5,500 ft-lbf, 600 rpm)

### Automatic Drop Hammer

229261 DH106 Automatic Drop Hammer  
 221820 Automatic Drop Hammer 170 lb. Expansion Kit  
 210126 Weight, 65 kg

### Mast / Winch

229259 Telescoping Dual Winch Mast  
 231152 Winch Kit: 6,800 lbf  
 230874 Winch Kit: 1,100 lbf with Quick Change Hook

### Breakout

229258 7 in. Breakout Kit

### Water / Mud Pumps

400101 Centrifugal Pump 3x2x13  
 230986 Moyno® 3L8 Pump

### Rotation Guard

230415 Safety Cage

### Toolboxes / Rod Racks

229287 10 Ft Tool Rack Asm Side Mount  
 212337 Underbody Storage Kit - Driller Side  
 212338 Underbody Storage Kit - Passenger Side

### Other

231032 Heater Display Kit  
 226601 Mud Tub, 175 Gal.  
 230956 Pull Cable E-stop Asm



4 Speed Combo Head (231236)



DH106 Automatic Drop Hammer (229261)



7 in. Breakout Kit (229258)



Moyno® 3L8 Pump (230986)



Safety Cage (230415)

