

## Dual Pivoting Jibs

Two jibs position primary and secondary winches.

- Primary – choose 17,500 or 12,000 lb; swings and extends to helper side.
- Secondary – choose 5,000, 2,500 or 1,800 lb; swings and extends to driller side.

## Drill Mast

Reach depth with ability to support weight of steel casing, rigid drill mast provides 28.5-foot stroke and 40,000 lb pullback.

## Rod Carousel

Backfeeding while running drill pipe frees helper to complete other site chores. Options accommodate preferred pipe size:

- 3.5-inch rod: 12 rods in carousel (240 feet) + 18 rods in optional box (360 feet) = 600 feet
- 4.5-inch rod: 10 rods in carousel (200 feet) + 15 rods in optional box (300 feet) = 500 feet

## Control Panel

Durable, mechanical controls simplify operation and training of new drillers. Organized control panel includes engine monitoring, safety E-stop, hydraulic pressure gauges, friction control levers for mud pump and rotation circuits, and electronic throttle controls.

## Top Head Carriage

2-speed rotary drive with 8,000 ft-lb torque, 200 rpm, and 3-inch spindle thru bore. Side shift both directions with 40 inches of total travel to work with carousel and create a clear path for centerline winch operation. Durable rollers instead of slides provide fast, smooth 28.5-foot stroke along with a quiet job site and simple maintenance.

## Mud Pump & Air Compressor

Drill larger, deeper using preferred drilling method.

- Air – choose between 500/200, 600/250 or 1070/350 compressor
- Mud – up to 6X8 piston pump along with 4X3 centrifugal pump, running independently or supercharge duplex with 4X3 running in front

## Table Assembly / Breakout Wrench

Hydraulically retract breakout table – quickly switching bushing sizes to provide a 24-inch opening located outside the drill mast for plenty of room to weld well casing. Utilize air fork for fast and safe tripping out.



Simplified Mud or Air Drilling suited for geothermal, water well, or irrigation projects, the DM650 is easily mobilized from job site to job site. The DM650 has many options available to suit your mud or air drilling requirements.

## DIMENSIONS

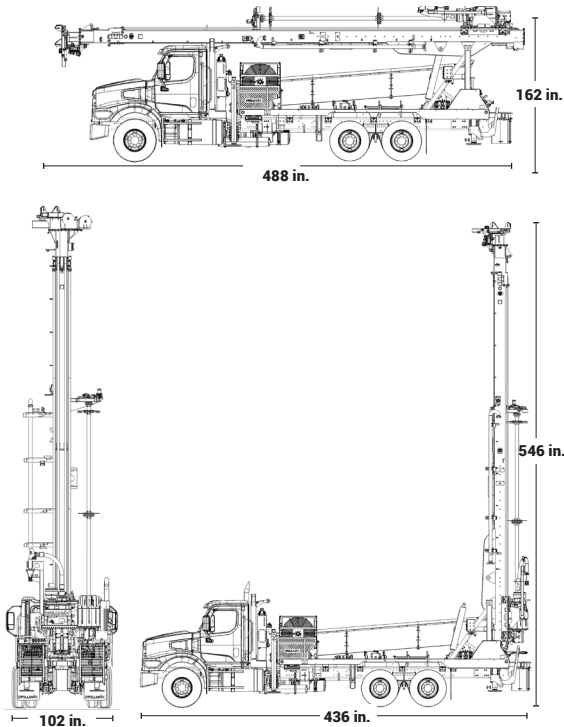

**Truck Chassis**  
Western Star® 49X factory chassis features a powerful 600 h.p. engine, 18-speed transmission, and nationwide dealership support.



**MD4 Display**  
The new Master Display (MD) features touchscreen or soft button navigation.

Rig shown with optional features. Dimensions subject to change without notice.

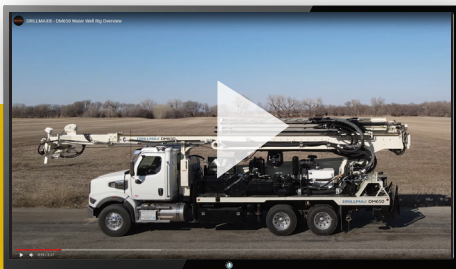

## OPTIONS

### Tool Handling

- Sub DM8 Flange X 3-1/2 IF Box
- Sub 3-1/2 IF Box X 3-1/2 IF Pin 24 S-S
- Float Sub DH 3-1/2 IF Box X 3-1/2 IF Pin 24 S-S
- Stabilizer Tray 10" OD X 15' Long
- Rod Spinner

### 3.5 OD Rod -- (2-3/8 IF)

- Centralizer Kit 3.6/6.8/10.9
- Fork Weldment 3.5" Drill Rod
- Sub 2-3/8 IF Box X 3-1/2 IF Pin
- Sub 2-3/8 IF Pin X 2-3/8 IF Pin
- Hoist Plug 2-3/8 IF - Backloading

### 4.5 OD Rod -- General

- Centralizer Kit 4.6/6.8/10.9
- Fork Weldment 4.5" Drill Rod

### 4.5 OD Rod (3-1/2 IF Specific)

- Sub 3-1/2 IF Box X 3-1/2 IF Pin 16 S-S
- Sub 3-1/2 IF Pin X 3-1/2 IF Pin 16 S-S
- Hoist Plug 3-1/2 IF - Backloading

### 4.5 OD Rod (2-7/8 IF Specific)

- Sub 2-7/8 IF Box X 3-1/2 IF Pin 16 S-S
- Sub 2-7/8 IF Pin X 2-7/8 IF Pin
- Hoist Plug 2-7/8 IF - Backloading
- Breakout Fork 2-7/8 IF

### Mud/Water Pumps

- Duplex Pump 5.5x8
- Duplex Pump 6x8
- Centrifugal Pump 4x3x13
- 6x8 Duplex + 4x3 Centr Pump
- 6x8 Duplex + 4x3 Centr Supercharge Pump
- Water Injection Pump
- Water Injection Kerr Triplex
- Hammer Lubricator
- 3 in. Diaphragm Pump

### Rod Loader / Box

- Single Rod Loader 3.5 in. Rod
- Rod Box 3.5 in. 25 Rod
- Single Rod Loader 4.5 in. Rod
- Rod Box 4.5 in. 15 Rod

### Carousel

- Carousel 3.5 in. x 12 Rod
- Carousel Rod Box 3.5 in. X 18 Rod
- Carousel 4.5 in. x 10 Rod
- Carousel Rod Box 3.5 in. X 15 Rod

### Air Compressor

- Air Compressor, 500/200 CFM
- Air Compressor, 1070/350 CFM

### Tool Storage

- Helper Toolbox 32 in.
- Drivers Side Toolbox HD 60 in.

### Additional Options

- Steerable Tag Axle
- Hammer Holder - 6"
- Hammer Holder - 8"
- Hammer Holder - 10"
- Foam Tank Kit -- 3 Gallons
- Secondary Aux Pump Kit
- Hydraulic Welder Kit
- Remote Cntl Primary Winch/Jib

## DM650 Air Rig Option



**TOOLING**

DRILLMAX® Drill Pipe

DRILLMAX® Spring Assisted Swivel Hoist Plug

DRILLMAX® Adapter Subs

Videos, Photos, Specifications, Resources

[drillmaxrigs.com/dm650](http://drillmaxrigs.com/dm650)